

**KESLA 2110Z, 2110ZT****Sisällysluettelo \ Innehållsförteckning \ Contents \ Inhaltsverzeichnis**

Pääkokoona-pano \ Sammansättning \ Final assembly \ Zusammensetzung .....	2
Käätölaite \ Vridanordning \ Slew mechanism \ Schwenkwerk .....	4
Tukijalkavarustus \ Stödbensutrustning \ Stabilizers \ Stützfußbausrüstung .....	8
Nostopuomi \ Lyftbom \ Main lifting boom \ Hubarm .....	46
Siirtopuomisto \ Vipparm KESLA \ Outer boom \ Knickarm .....	50
Vetotanko varusteltuna \ Dragstång \ Inner link assy \ Mittleres Gelenk .....	64
Siirtopuomiston ketju \ Kedja \ Chain \ Kette kompl. \ 3x4 (77) .....	66
Siirtopuomiston ketju \ Kedja \ Chain \ Kette kompl. \ 3x4 (87) .....	68
Nostosylinteri varusteltuna \ Lyftcylinder utrustning \ Accessories for main lifting cylinder \ Ausrüstung für Hubzylinder .....	70
Nostosylinteri \ Lyftcylinder \ Main lifting cylinder \ Hubzylinder .....	72
Siirtosylinteri varusteltuna \ Vippcylinder utrustning \ Accessories for outer boom cylinder \ Ausrüstung für Knickarmzylinder .....	74
Siirtosylinteri \ Vippcylinder \ Outer boom cylinder \ Knickarmzylinder .....	76
Jatkeen sylinteri \ Utskjutscylinder \ Extension cylinder \ Ausschubzylinder \ .....	78
Tukijalkojen levityssylinteri \ Spridningscylinder \ Spreading cylinder \ Ausshubzylinder für Stützfüsse .....	80
Tukijalan sylinteri \ Stödbenscylinder \ Stabilizer cylinder \ Stützfußcylinder .....	82
Kiinnityssarja \ fastsättning kit \ Fastening kit \ Montagesatz .....	84

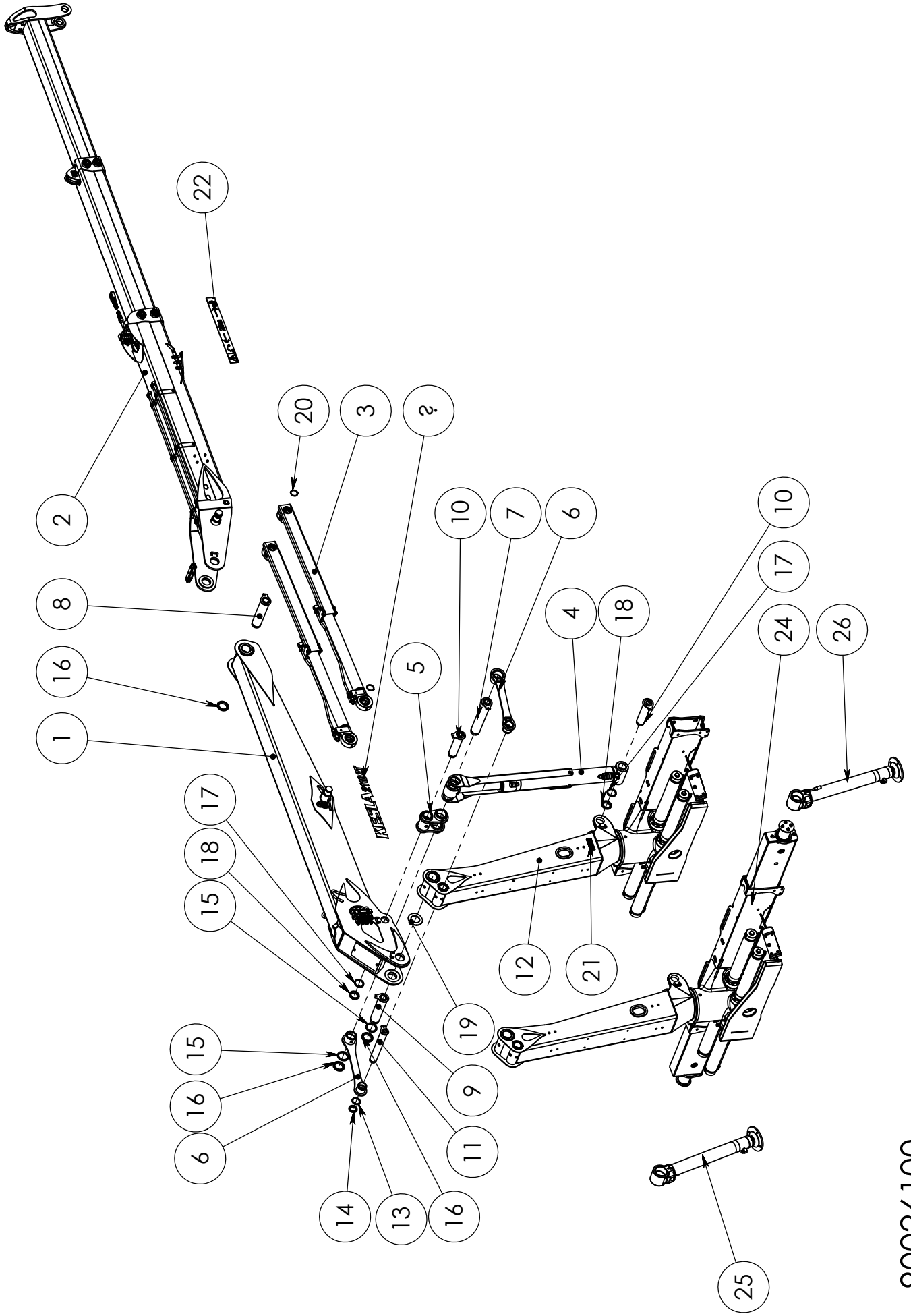



## SPARE PART LIST

Item code	90026100	Revision	-
Title	CRANE	Date	08.02.2013
Specification	2110ZT L=9500		

Pos	Item code	Title	Specification	Pc	Nto Weight
1	90025636	LIFT BOOM	3520 RIGHT VAR	1	271.54
2	90025642	OUTER BOOM	L=6200 2-JATK	1	380.03
3	90025549	CYLINDER	80/60X880 VAR	2	69.1
4	90025620	CYLINDER	120/80 X 921 NOSTOSTYLINTERI 2110Z	1	94.14
5	90025497	DRAW BAR	VAR	1	10.7
6	90025483	LINK	L=560 HITS+KON	2	7.97
7	90021057	AXLE	80-435 HITS	1	11.71
8	90018761	AXLE	80/M75X2 -352	1	9.51
9	90015226	AXLE	80/M75-333	1	8.96
10	90015998	AXLE	70/M65X2-298 HITS	2	6.75
11	90025504	AXLE	60/M55X2-432	1	7.04
12	90025629	SLEW MECHANISM	RIGHT	1	665.34
13	90013698	WASHER	75/61-6	1	0.07
14	3020164	NUT	KM11 NYLOC M55X2.0	1	0.17
15	90013697	WASHER	100/81-6	2	0.13
16	3020158	NUT	KM15 NYLOC M75X2	3	0.35
17	90016000	WASHER	85/71-6	2	0.08
18	3020157	NUT	KM13 NYLOC M65X2.0	2	0.26
19	90010011	BEARING	130/80.5 - 5	2	0.05
20	3060098	SNAP RING	60X3 DIN 471 AS	6	0
21	3280507	PLATE	MALLICE (120X45) LIIMATTAVA TUOTEKILPI	1	0.03
22	3281135	DECAL	VAARA-ALUE 25 M. 730X80	2	0.1
23	3281545	DECAL	KESLA 2110ZT	2	0.07
24	90025649	STABILIZER	L=3840 RIGHT	1	111.86
25	90025603	STABILIZER	90/70X620 RIGHT (FIXED FOOT)	1	63.26
26	90025604	STABILIZER	90/70X620 LEFT (FIXED FOOT)	1	63.26

90025629

2110Z SLEW MECHANISM

RIGHT

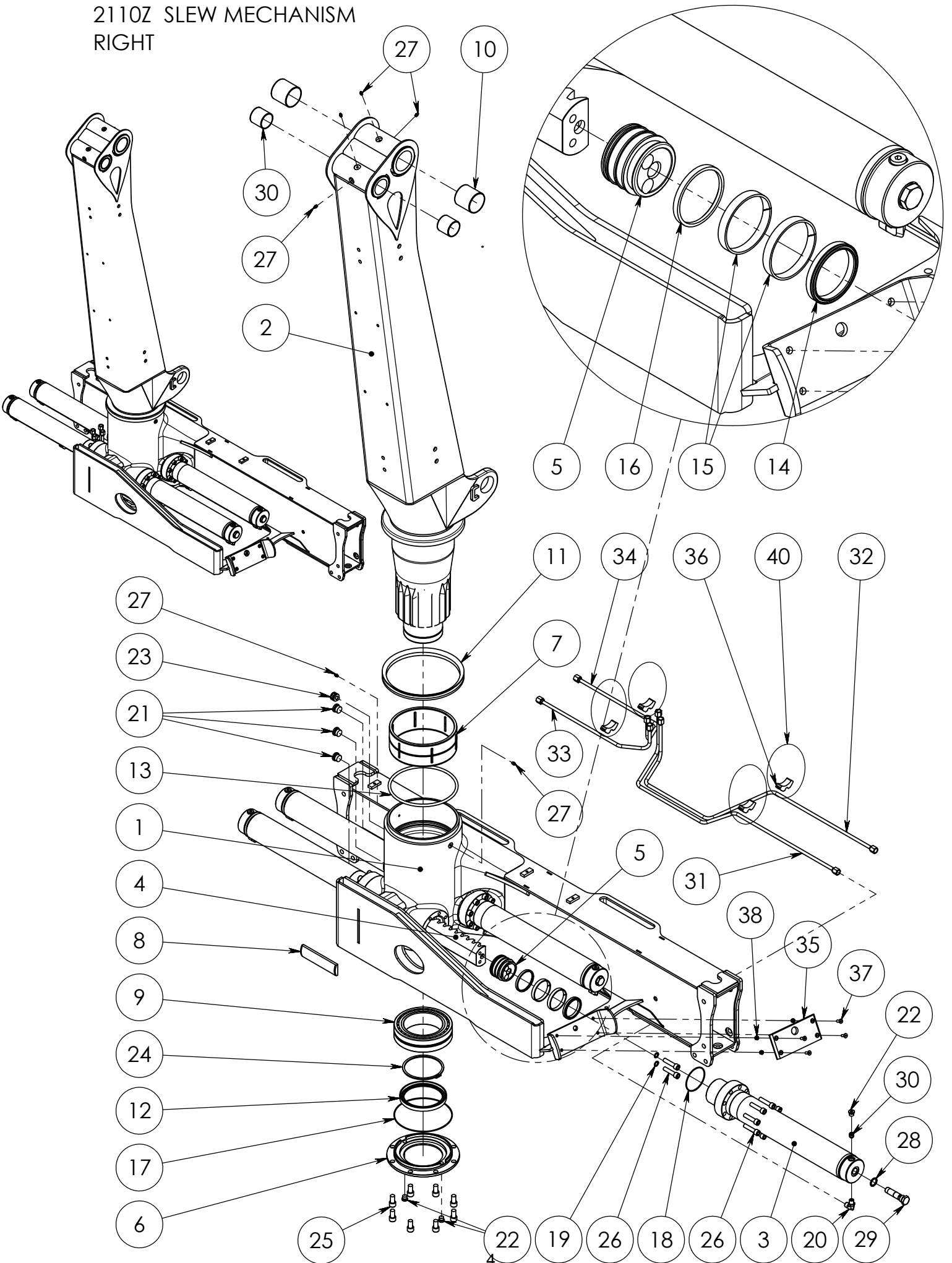

Item code	90025629	Revision	A
Title	SLEW MECHANNISM	Date	28.06.2012
Specification	RIGHT		

Pos	Item code	Title	Specification	Pc	Nfo Weight
1	90025622	SLEW MECHANNISM	RUNKO OIKEA HITS	1	284.07
2	90025474	PILLAR	L=2390 HITS + KON	1	239.11
3	90024152	CYLINDER	105/90-762	4	17.37
4	90025435	RACK BAR		2	19.93
5	90024154	PISTON	90-67	4	2.14
6	90021820	FLANGE	280/150-28	1	4
7	90012821	BEARING	260/240-100	1	0.88
8	90025436	BUSHING	50X189	2	0.15
9	3100331	ROLLER BEARING	23030CC/W33	1	7.45
10	3100187	BUSHING	WB 802 8080	2	0.41
11	3110930	SEAL	VA-300	1	1.63
12	3110565	SHAFT SEAL	150X180X15 RST	1	0.5
13	3110938	SEAL	OR 250X10 70SHORE	1	0.5
14	3110636	PISTON SEAL	B7 90/75X12	4	0.16
15	3110637	PISTON GUIDE	E/PWR 90/84X13	8	0.08
16	3110638	WIPER SEAL	PPW 90/81.4X5.3	4	0.05
17	3110771	O-RING	219.5X3.0 70 SHORE	1	0.04
18	3110639	O-RING	96X3.0 70 SHORE	4	0.02
19	3030080	WASHER	M14	8	0
20	3090630	CONNECTOR (ANGLE)	6310-06-08	4	0.1
21	3090209	PLUG		3	0.08
22	3090210	PLUG		6	0.03
23	3091042	BREATHER		1	0.11
24	3060076	SNAP RING	AS 150X4 DIN 471	1	0
25	3010700	ALLEN SCREW	M16X30 8.8 ZN DIN 912	8	0
26	3010601	ALLEN SCREW	M14X60 12.9 DIN 912	40	0
27	3050003	GREASE NIPPLE	M8X1,25 DIN 71412	6	0
28	3110130	USIT-SEAL	R-12 R 3/4"	4	0.01
29	90023662	DAMPER	D=21,8	4	0.31
30	3120363	CHECK VALVE		4	0.02
31	3100194	BUSHING	WB 802 6060	2	0.23
32	90024395	HYDRAULIC PIPE	1 RIGHT	1	0.64
33	90024393	HYDRAULIC PIPE	2 RIGHT	1	0.66
34	90024389	HYDRAULIC PIPE	3 RIGHT	1	0.33
35	90024391	HYDRAULIC PIPE	4 RIGHT	1	0.33
36	90018948	GLIDE PAD	100 X 220	1	0.22

Item code	90025629	Revision	A
Title	SLEW MECHANNISM	Date	28.06.2012
Specification	RIGHT		

Pos	Item code	Title	Specification	Pc	Nfo Weight
37	3090928	FASTENER		4	0.22
38	3010300	ALLEN SCREW	M8X25 10.9 ZN DIN 7991	4	0
39	3020001	NUT	M8 ZN DIN 985	4	0.01
40	3090409	TENSIONER		4	
41	3110640	SEAL KIT	90	1	0



90025612

2110Z STABILIZER L=3840 LEFT/ RIGHT

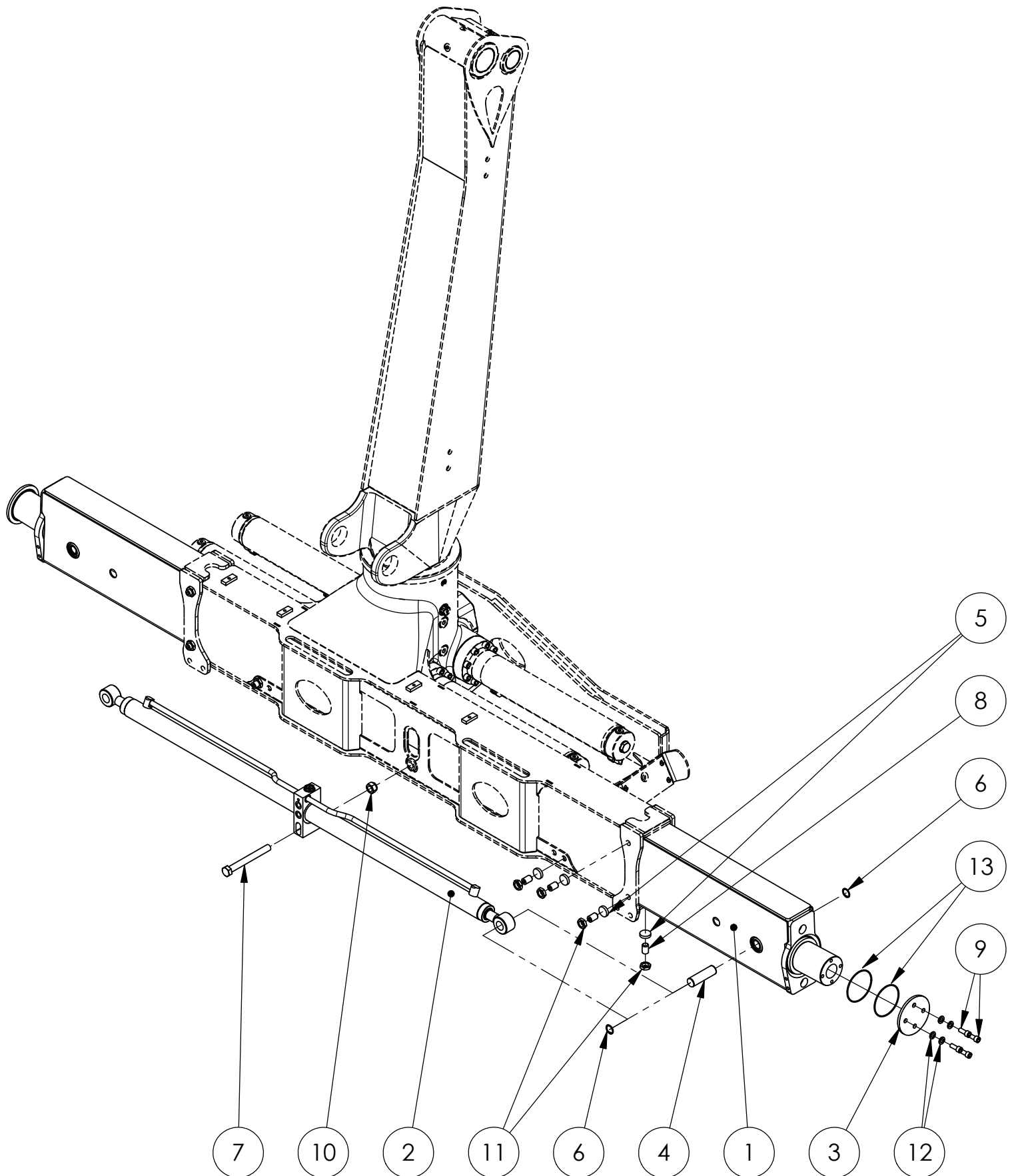



Item code	90025612	Revision	-
Title	STABILIZER	Date	20.06.2012
Specification	L=3840 LEFT/ RIGHT		

Pos	Item code	Title	Specification	Pc	Nto Weight
1	90025449	CONTROL ARM	HITS	2	40.47
2	28864001	SPREADING CYLINDER	50/30X2X650	1	27.75
3	90011250	FLANGE	135 - 8	2	0.86
4	90013050	AXLE	30-102	2	0.57
5	90020807	GLIDE PAD	35 - 8	8	0.01
6	3060019	SNAP RING	30 DIN 472	4	0
7	3010224	HEW SCREW	M20X180 8.8 ZN DIN 931	1	0
8	3010312	ALLEN SCREW	M20X30 10.9 ZN DIN 913	8	0
9	3010246	ALLEN SCREW	M12X30 8.8 ZN DIN 912	8	0
10	3020009	NUT	M20 ZN DIN 985	1	0.07
11	3020014	NUT	M20 ZN DIN 936	8	0
12	3030047	WASHER	M12/13 ZN DIN 126	8	0.01
13	3110259	O-RING	104.5X3 90 SHORE	4	0.02

90026206  
90/70x450 LEFT ( ADJUSTABLE FOOT )

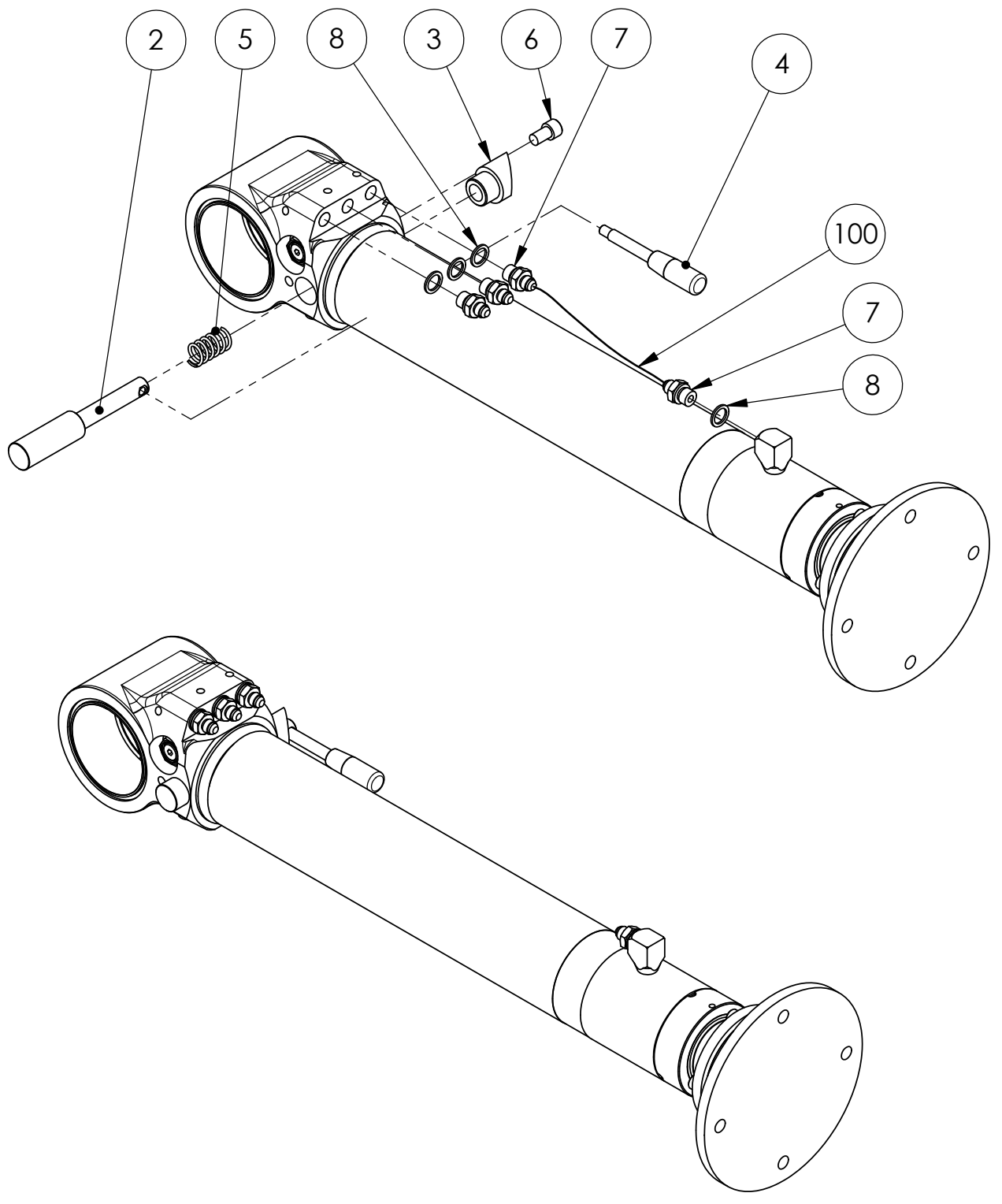

Item code	90026206	Revision	-
Title	STABILIZER	Date	26.02.2013
Specification	90/70X450 LEFT ( ADJUSTABLE FOOT )		

Pos	Item code	Title	Specification	Pc	Nto Weight
1	28957001	CYLINDER	90/70X450	1	58.67
2	90025017	SPINDLE	30/18-179	1	0.63
3	90025018	SLEEVE		1	0.26
4	3301574	LEVER	GN 310-12-125-E-NI M10	1	0.03
5	3300533	SPRING	18/45/7.6/6.88 -1643 SF-TF3	1	0.02
6	3010604	ALLEN SCREW	M12X20 8.8 DIN 912	1	0
7	3090901	CONNECTOR	6010-06-06	4	0.05
8	3110040	USIT-SEAL	R-06 R 3/8"	4	0
100	3133276	HYDRAULIC HOSE	A50005-06-06/241T-06/A50005-06-06/L=560/ TEX	1	0

90026208  
90/70x450 RIGHT ( ADJUSTABLE FOOT )

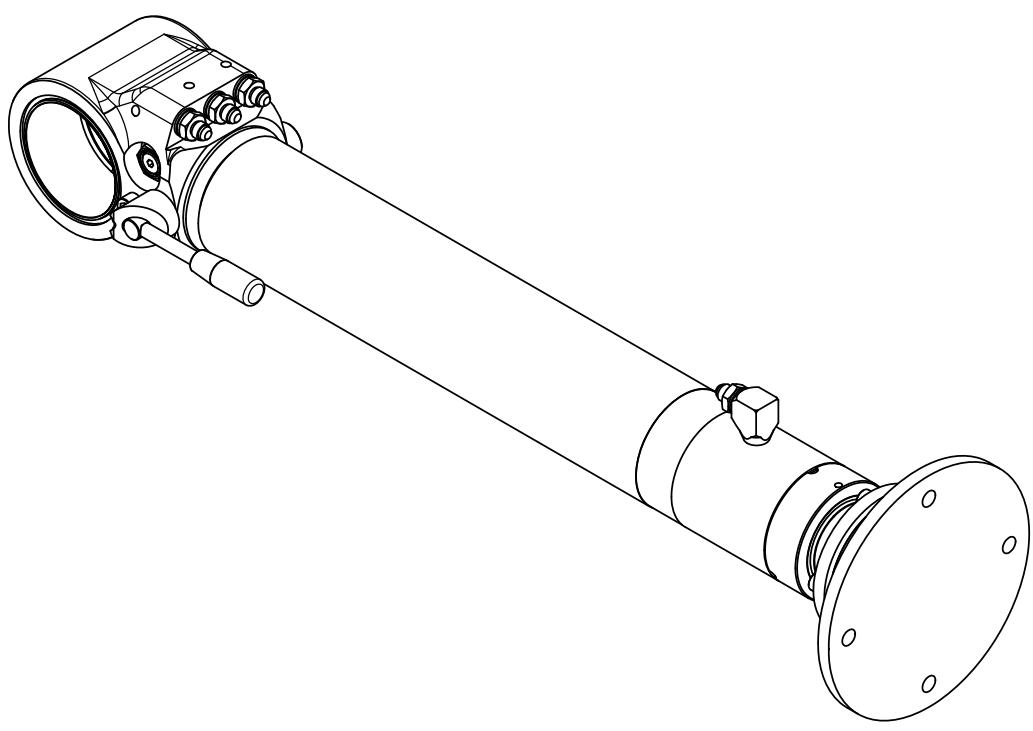
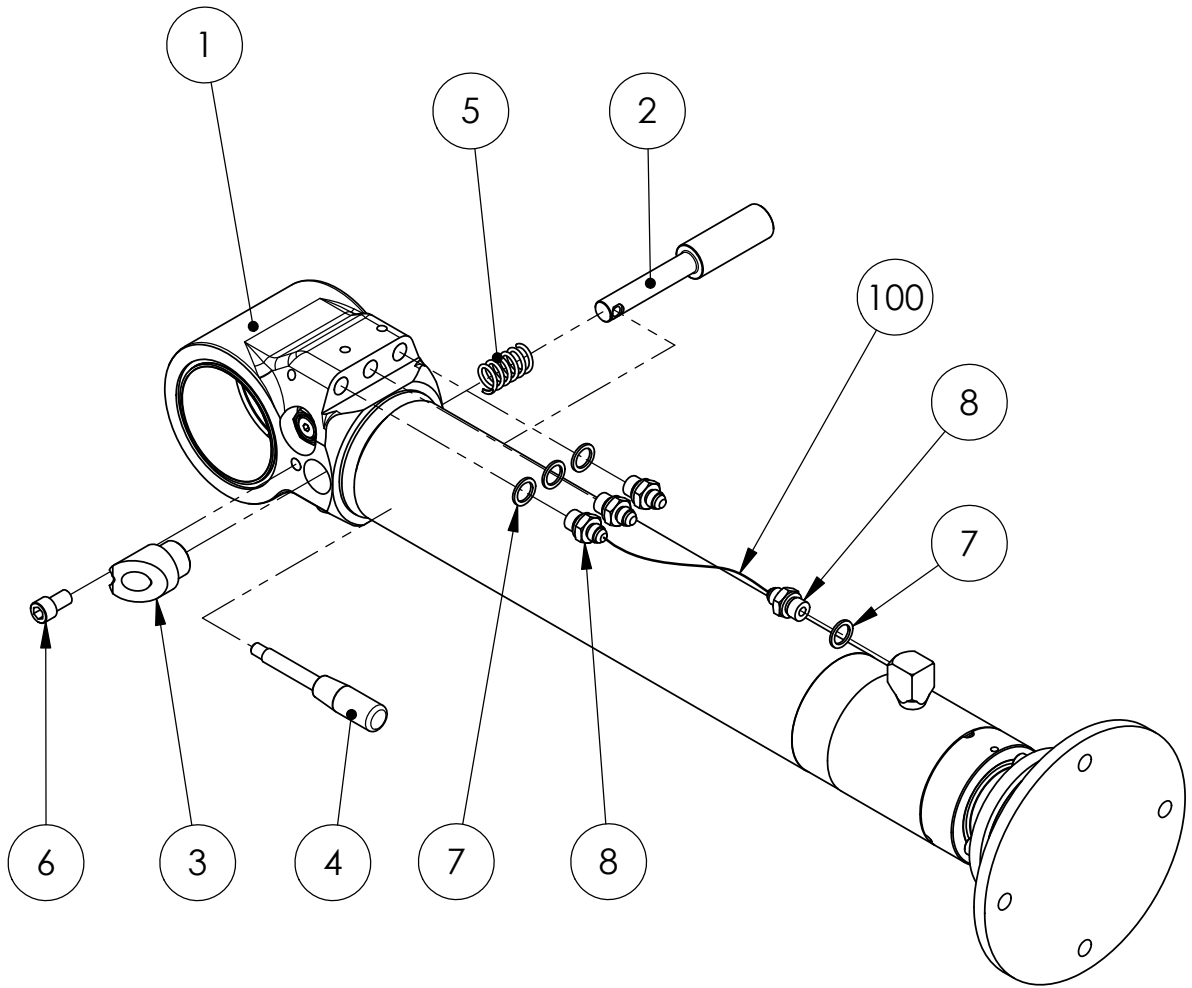

Item code	90026208	Revision	-
Title	STABILIZER	Date	26.02.2013
Specification	90/70X450 RIGHT ( ADJUSTABLE FOOT )		

Pos	Item code	Title	Specification	Pc	Nto Weight
1	28957001	CYLINDER	90/70X450	1	58.67
2	90025017	SPINDLE	30/18-179	1	0.63
3	90025018	SLEEVE		1	0.26
4	3301574	LEVER	GN 310-12-125-E-NI M10	1	0.03
5	3300533	SPRING	18/45/7.6/6.88 -1643 SF-TF3	1	0.02
6	3010604	ALLEN SCREW	M12X20 8.8 DIN 912	1	0
7	3110040	USIT-SEAL	R-06 R 3/8"	4	0
8	3090901	CONNECTOR	6010-06-06	4	0.05
100	3133276	HYDRAULIC HOSE	A50005-06-06/241T-06/A50005-06-06/L=560/ TEX	1	0

28957001

# SYLINTERI

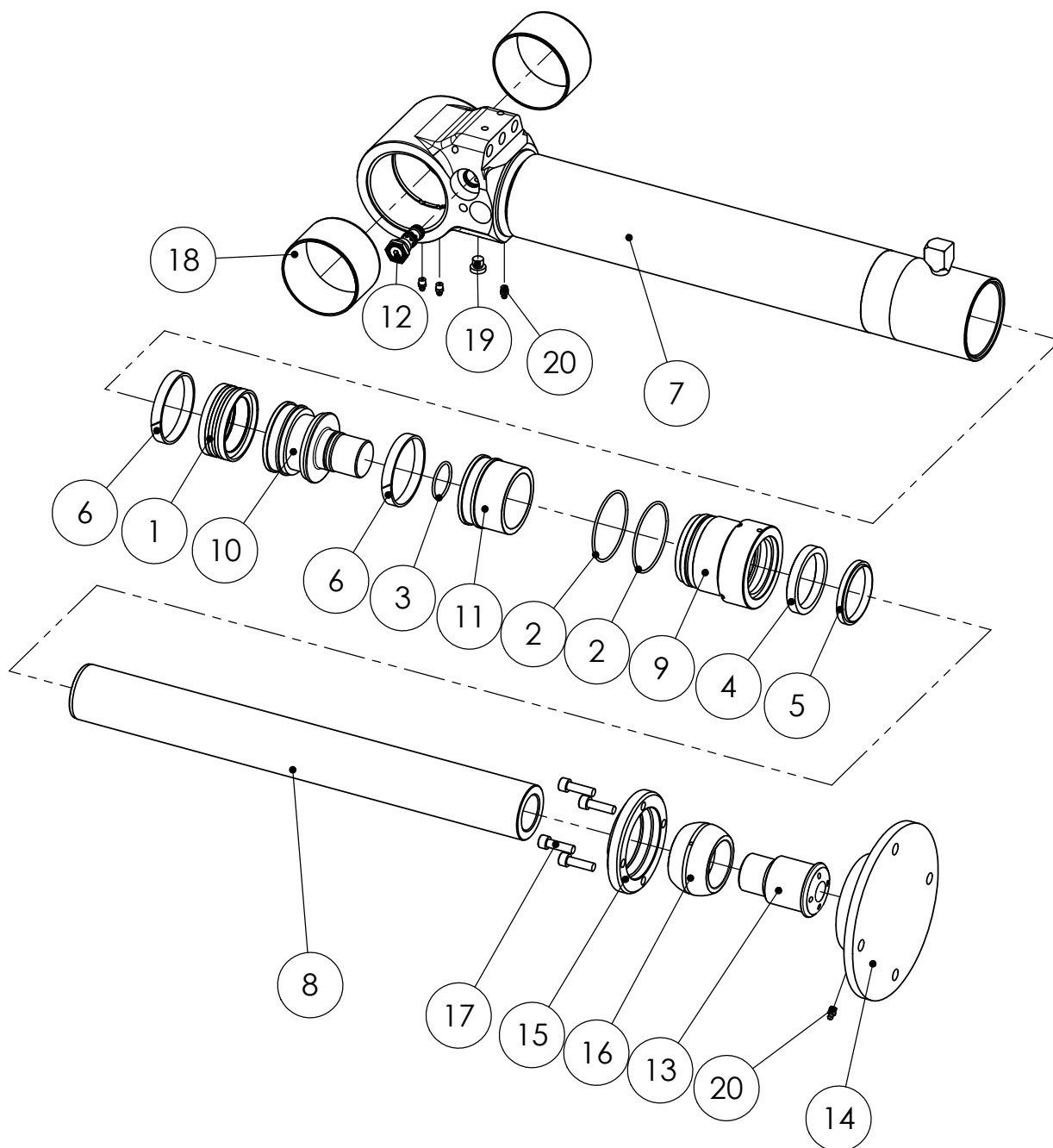

Item code	28957001	Revision	-
Title	CYLINDER	Date	25.02.2013
Specification	90/70X450		

Pos	Item code	Title	Specification	Pc	Nto Weight
1	3110025	PISTON SEAL	DAS 90/70X22	1	0.5
2	3110017	O-RING	84.5X3 90 SHORE	2	0.02
3	3110258	O-RING	42.2X3 90 SHORE	1	0.01
4	3110184	ROD SEAL	B 70/85X12 POLYPAC BALSELE	1	0.17
5	3110196	WIPER SEAL	GA 70/80X7/10	1	0.07
6	3110397	PISTON GUIDE	E/PWR 90/84X13	2	0.08
7	28956101	CYLINDER BARREL	90/70X450	1	29.48
8	28956302	PISTON ROD	70/42-623	1	11.82
9	28358202	GUIDANCE	90/70	1	2.42
10	28942201	PISTON	90	1	2.46
11	28554105	SLEEVE	ISKURAJOITINHOLKKI	1	0.96
12	3120843	VALVE		1	0.13
13	28944401	AXLE	60/M47	1	1.9
14	28861106	BASE		1	5.55
15	28861107	COVER		1	1.07
16	3100428	BEARING	NIVELLAAKERIN PALLO GEF 60 ES	1	1.14
17	3010970	ALLEN SCREW	M10X35 12.9 DIN 912	4	0
18	3100344	BUSHING	WB 802 10060	2	0.38
19	3090211	PLUG		1	0.02
20	3050003	GREASE NIPPLE	M8X1,25 DIN 71412	4	0
1-6	3111025	SEAL KIT	90/70	1	

90026135  
90/70x450 LEFT ( FIXED FOOT )

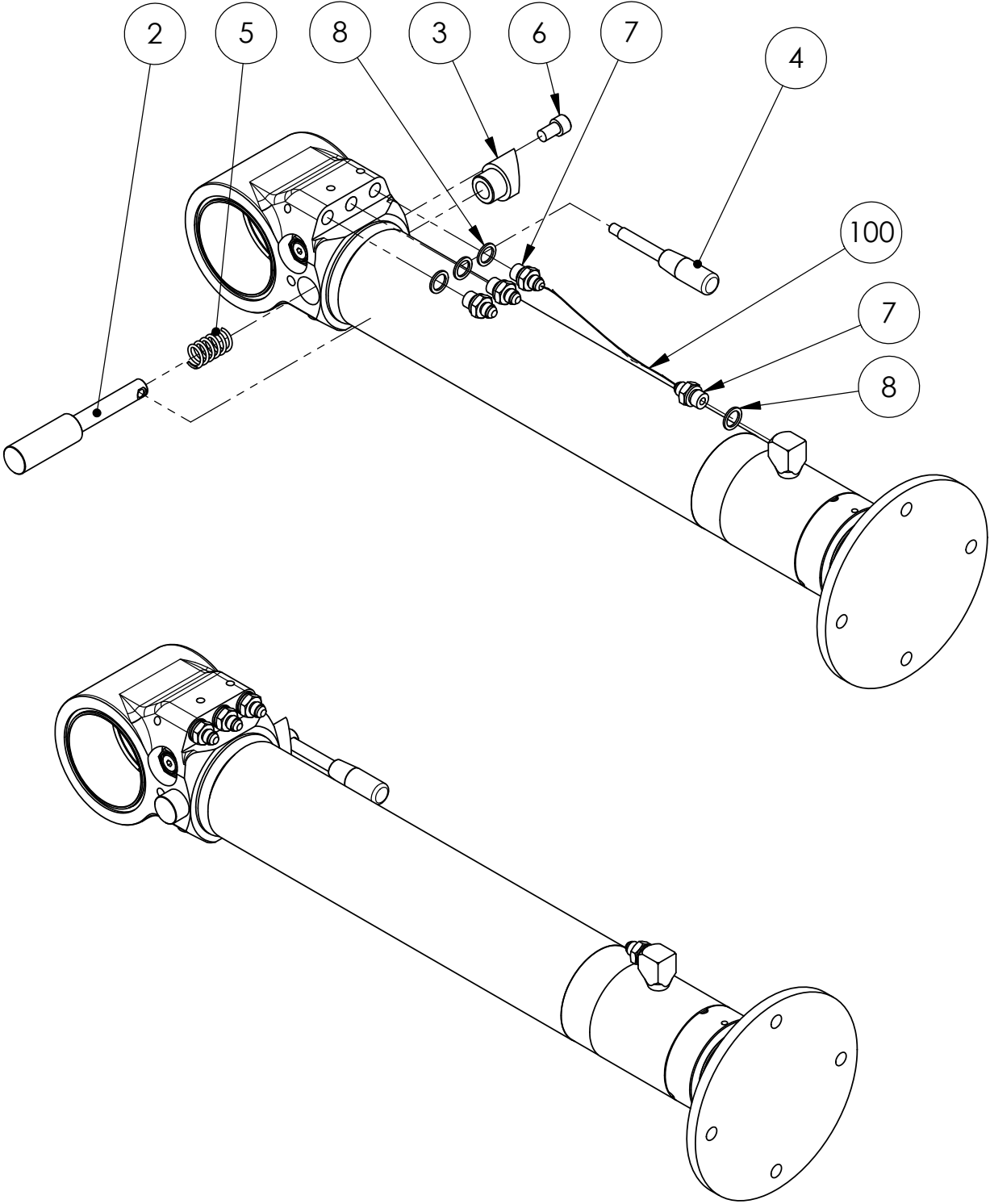



Item code	90026135	Revision	-
Title	STABILIZER	Date	19.02.2013
Specification	90/70X450 LEFT ( FIXED FOOT )		

Pos	Item code	Title	Specification	Pc	Nto Weight
1	28956001	CYLINDER	90/70X450	1	55.08
2	90025017	SPINDLE	30/18-179	1	0.63
3	90025018	SLEEVE		1	0.26
4	3301574	LEVER	GN 310-12-125-E-NI M10	1	0.03
5	3300533	SPRING	18/45/7.6/6.88 -1643 SF-TF3	1	0.02
6	3010604	ALLEN SCREW	M12X20 8.8 DIN 912	1	0
7	3090901	CONNECTOR	6010-06-06	4	0.05
8	3110040	USIT-SEAL	R-06 R 3/8"	4	0
100	3133276	HYDRAULIC HOSE	A50005-06-06/241T-06/A50005-06-06/L=560/ TEX	1	0

90026137  
90/70x450 RIGHT ( FIXED FOOT )

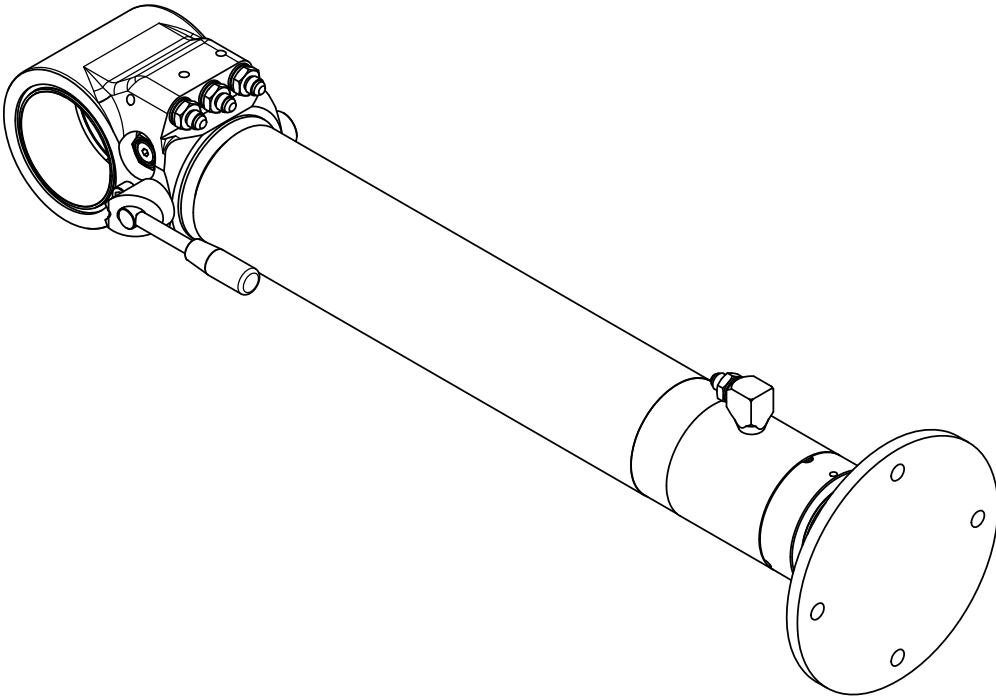
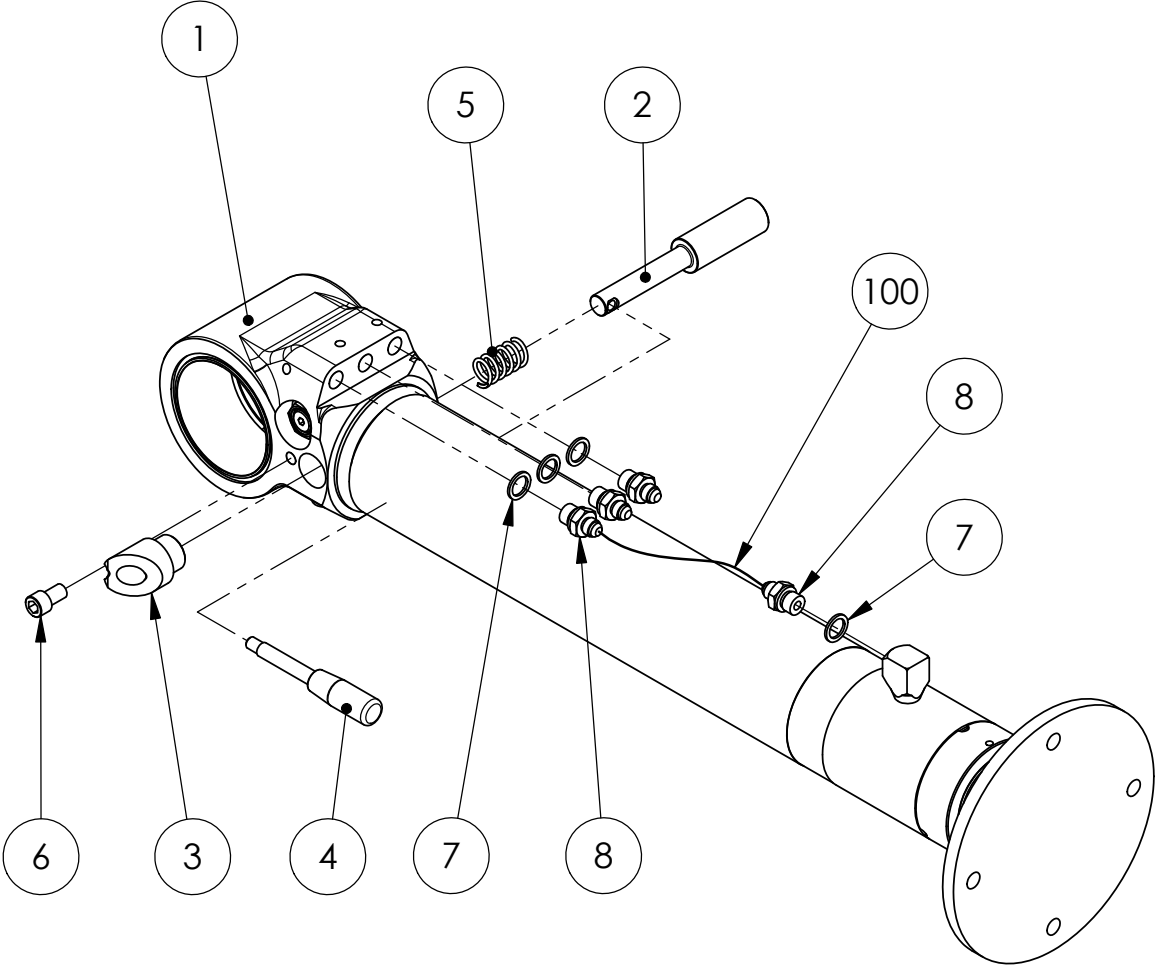

Item code	90026137	Revision	-
Title	STABILIZER	Date	19.02.2013
Specification	90/70X450 RIGHT ( FIXED FOOT )		

Pos	Item code	Title	Specification	Pc	Nto Weight
1	28956001	CYLINDER	90/70X450	1	55.08
2	90025017	SPINDLE	30/18-179	1	0.63
3	90025018	SLEEVE		1	0.26
4	3301574	LEVER	GN 310-12-125-E-NI M10	1	0.03
5	3300533	SPRING	18/45/7.6/6.88 -1643 SF-TF3	1	0.02
6	3010604	ALLEN SCREW	M12X20 8.8 DIN 912	1	0
7	3110040	USIT-SEAL	R-06 R 3/8"	4	0
8	3090901	CONNECTOR	6010-06-06	4	0.05
100	3133276	HYDRAULIC HOSE	A50005-06-06/241T-06/A50005-06-06/L=560/ TEX	1	0

28956001

# SYLINTERI

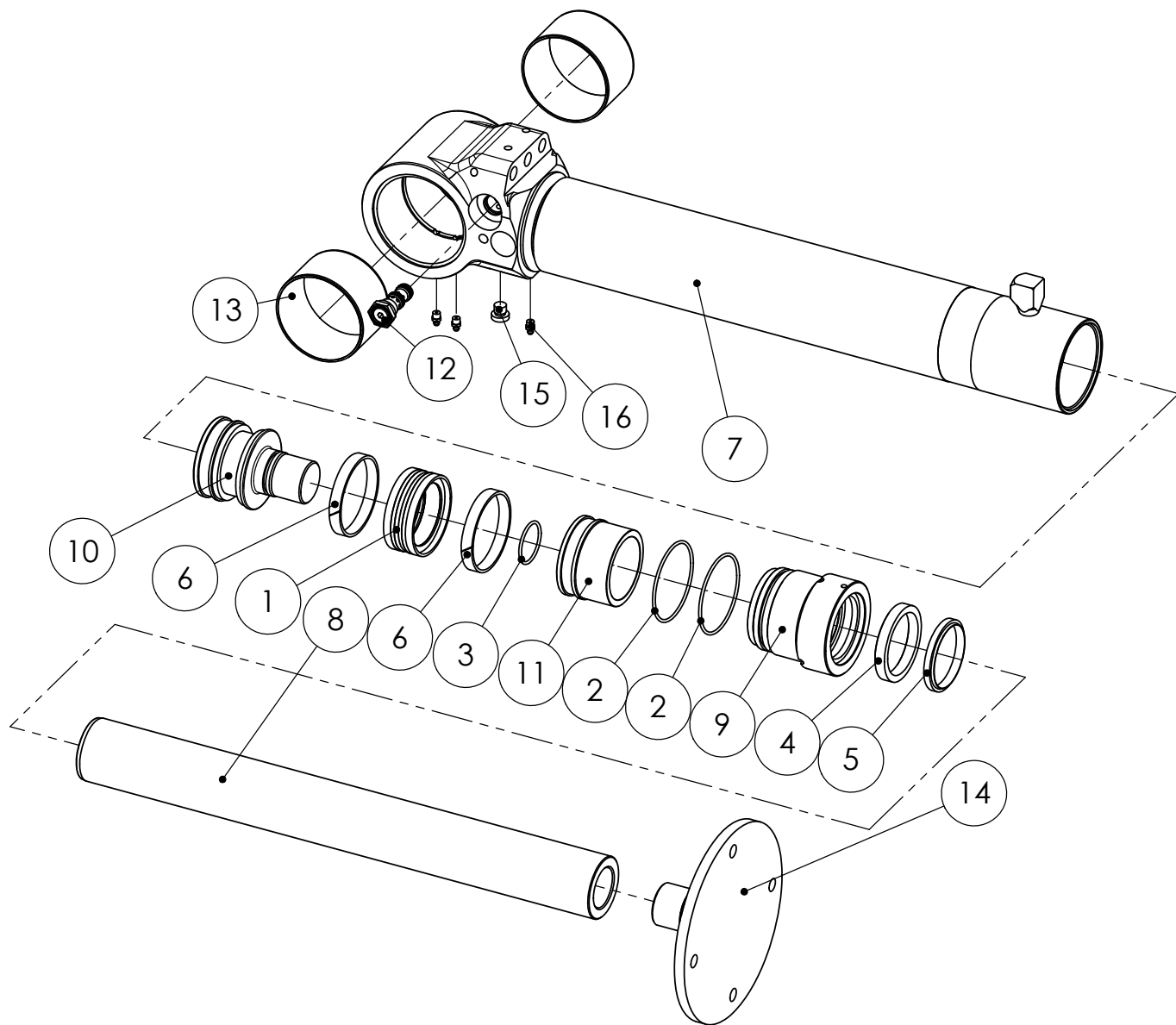

Item code	28956001	Revision	-
Title	CYLINDER	Date	27.05.2013
Specification	90/70X450		

Pos	Item code	Title	Specification	Pc	Nto Weight
1	3110025	PISTON SEAL	DAS 90/70X22	1	0.5
2	3110017	O-RING	84.5X3 90 SHORE	2	0.02
3	3110258	O-RING	42.2X3 90 SHORE	1	0.01
4	3110184	ROD SEAL	B 70/85X12 POLYPAC BALSELE	1	0.17
5	3110196	WIPER SEAL	GA 70/80X7/10	1	0.07
6	3110397	PISTON GUIDE	E/PWR 90/84X13	2	0.08
7	28956101	CYLINDER BARREL	90/70X450	1	29.48
8	28956302	PISTON ROD	70/42-623	1	11.82
9	28358202	GUIDANCE	90/70	1	2.42
10	28942201	PISTON	90	1	2.46
11	28554105	SLEEVE	ISKURAJOITINHOLKKI	1	0.96
12	3120843	VALVE		1	0.13
13	3100344	BUSHING	WB 802 10060	2	0.38
14	28942106	BASE	TUKIJALKA	1	6.07
15	3090211	PLUG		1	0.02
16	3050003	GREASE NIPPLE	M8X1,25 DIN 71412	3	0
1-6	3111025	SEAL KIT	90/70	1	

90025603  
90/70x620 RIGHT ( FIXED FOOT )

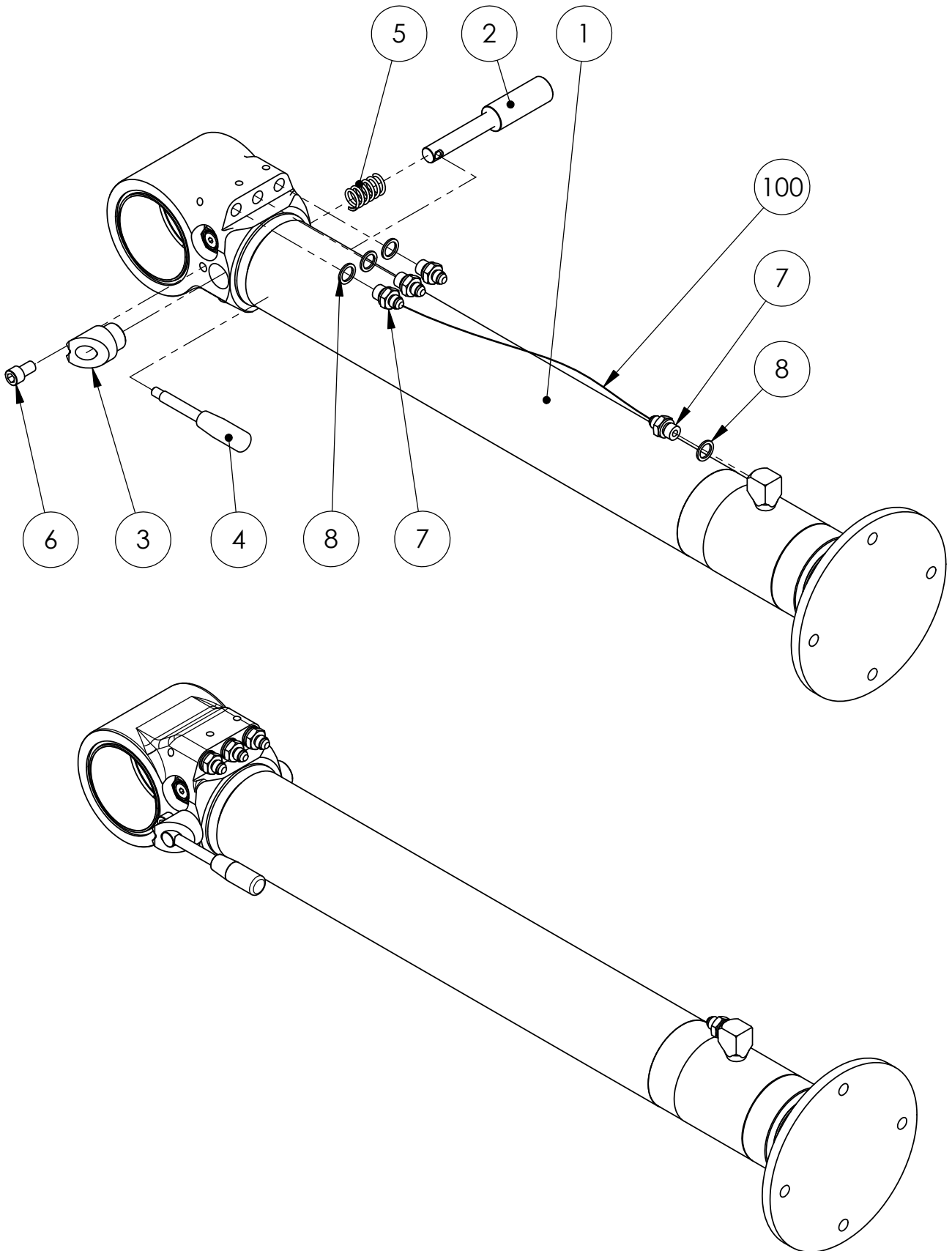

Item code	90025603	Revision	A
Title	STABILIZER	Date	18.06.2012
Specification	90/70X620 RIGHT ( FIXED FOOT )		

Pos	Item code	Title	Specification	Pc	Nto Weight
1	28943001	CYLINDER	90/70X620	1	61.43
2	90025017	SPINDLE	30/18-179	1	0.63
3	90025018	SLEEVE		1	0.26
4	3301574	LEVER	GN 310-12-125-E-NI M10	1	0.03
5	3300533	SPRING	18/45/7.6/6.88 -1643 SF-TF3	1	0.02
6	3010604	ALLEN SCREW	M12X20 8.8 DIN 912	1	0
7	3090901	CONNECTOR	6010-06-06	4	0.05
8	3110040	USIT-SEAL	R-06 R 3/8"	4	0
100	3132961	HYDRAULIC HOSE	A50005-06-06/241T-06/A50005-06-06S/L=730/TEX	1	

90025604

90/70x620 LEFT ( FIXED FOOT )

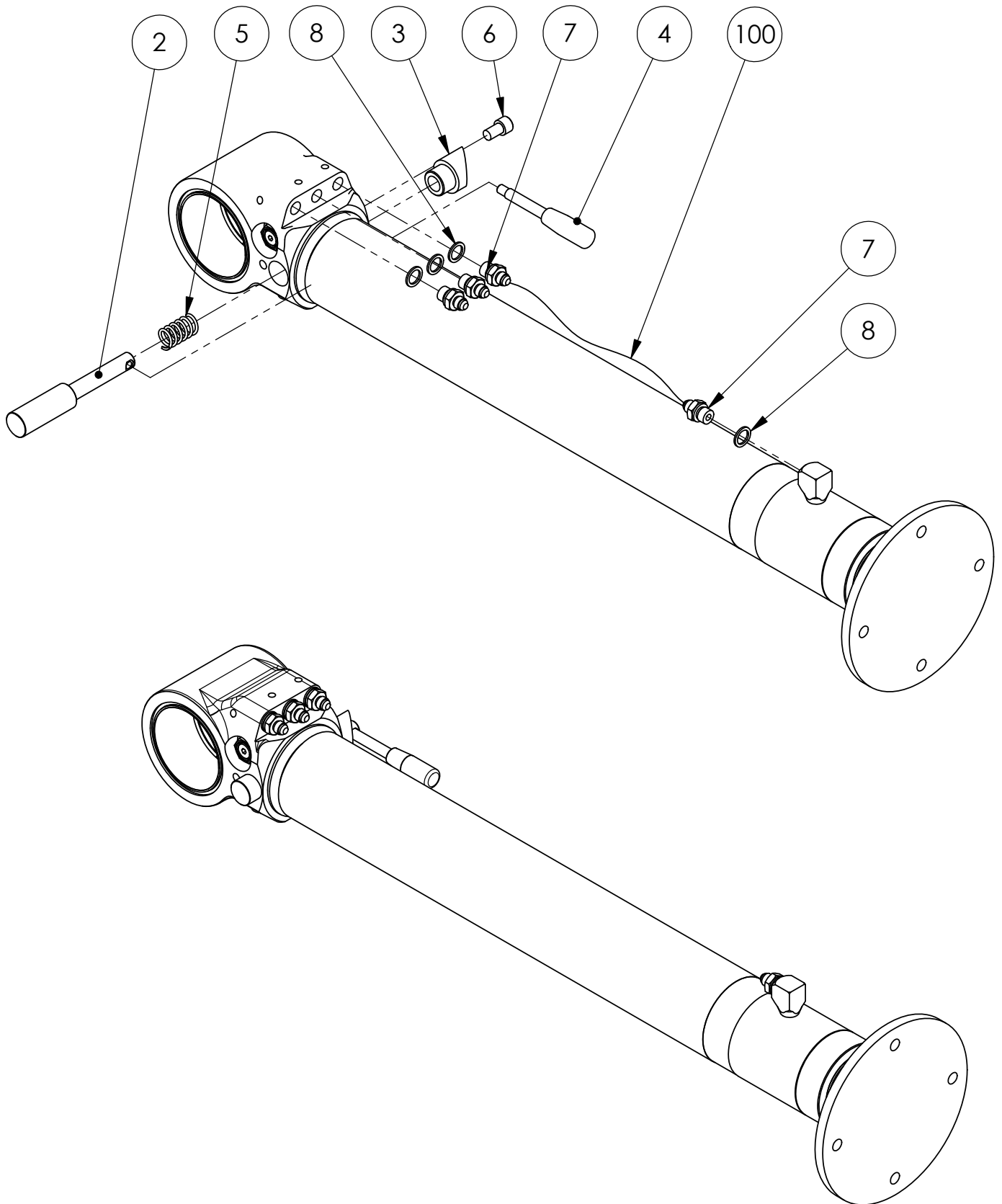



Item code	90025604	Revision	A
Title	STABILIZER	Date	18.06.2012
Specification	90/70X620 LEFT ( FIXED FOOT )		

Pos	Item code	Title	Specification	Pc	Nto Weight
1	28943001	CYLINDER	90/70X620	1	61.43
2	90025017	SPINDLE	30/18-179	1	0.63
3	90025018	SLEEVE		1	0.26
4	3301574	LEVER	GN 310-12-125-E-NI M10	1	0.03
5	3300533	SPRING	18/45/7.6/6.88 -1643 SF-TF3	1	0.02
6	3010604	ALLEN SCREW	M12X20 8.8 DIN 912	1	0
7	3090901	CONNECTOR	6010-06-06	4	0.05
8	3110040	USIT-SEAL	R-06 R 3/8"	4	0
100	3132961	HYDRAULIC HOSE	A50005-06-06/241T-06/A50005-06-06S/L=730/TEX	1	

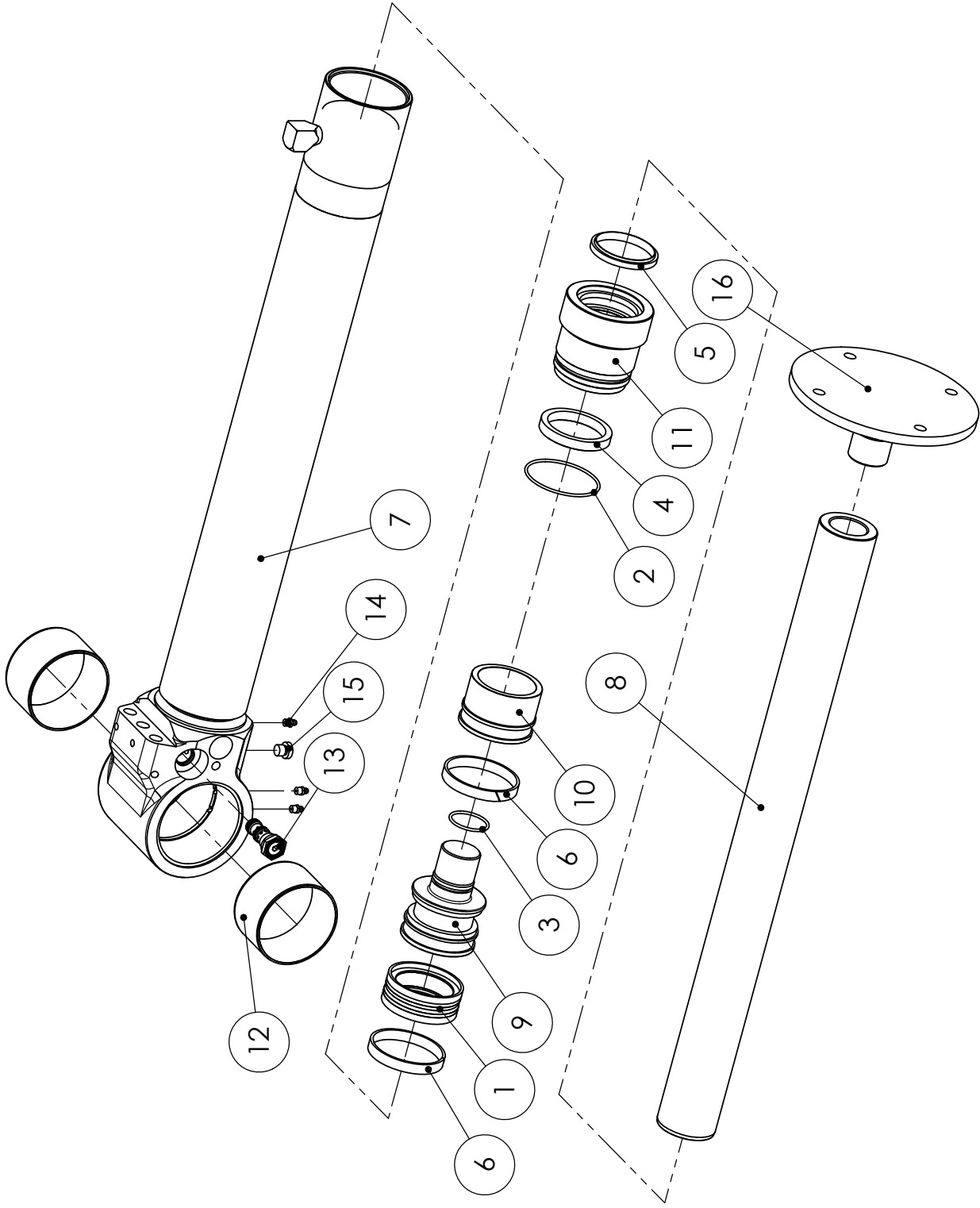

28943001 SYLINTERI



## SPARE PART LIST

Item code	28943001	Revision	-
Title	SYLINTERI	Date	15.01.2013
Specification	90/70X620		

Pos	Item code	Title	Specification	Dimensions	Pc	Amount	Unit	Nto Weight
1	3110025	MÄNNÄNTIIVISTE KOLV TÄTNING PISTON SEAL KOLBENDICHTUNG	DAS 90/70X22		1			0.5
2	3110017	O-RENGAS O-RING O-RING O-RING	84.5X3 90 SHORE		2			0.02
3	3110258	O-RENGAS O-RING O-RING O-RING	42.2X3 90 SHORE		1			0.01
4	3110184	VARRENTIIVISTE KOLVSTÄNGSTÄTNING ROD SEAL DICHTUNG FÜR KOLBENSTANGE	B 70/85X12 POLYPAC BALSELE		1			0.17
5	3110196	LUOVUJTIN AVSTRYKARE WIPER SEAL ABSTREIFER	GA 70/80X7/10		1			0.07
6	3110397	MÄNNÄNOHJAIN KOLV STYRNING PISTON GUIDE KOLBENFÜHRUNG	E/PWR 90/84X13		2			0.08
7	28861101	SYLINTERIPUTKI CYLINDERROHR	90/70X600		1			32.54
8	28943302	MÄNNÄNVARSI KOLVSTÄNG PISTON ROD KOLBENSTANGE	70-793		1			15.11
9	28942201	MÄNTÄ KOLV PISTON KOLBEN	90	L=122	1			2.46
10	28554105	HOLKKI HYLSA SLEEVE ACHSHALTER	ISKURAJOITINHOLKKI	L=62	1			0.96
11	28358202	OHJAIN STYRNING GUIDANCE STEUERUNG	90/70		1			2.43
12	3100344	LIUKULAAKERI BUSSNING BUSHING GLEITLAGER	WB 802 10060		2			0.38
13	3120843	VENTTIILI VENTIL VALVE VENTIL			1			0.13
14	3050003	RASVANIPPA SMÖRNIPPEL GREASE NIPPLE SCHMIERNIPPEL	M8X1,25 DIN 71412		3			0
15	3090211	TULPPA PLUGG PLUG DECKEL			1			0.02
16	28942106	ANTURA BOTTEN BASE UNTERLAGE	TUKIJALKA		1			6.07
1-6	3111025	TIIVISTESARJA TÄTNINGSATS SEAL KIT DICHTUNGSSATZ	90/70		1			

90025605  
90/70x520 RIGHT ( FIXED FOOT )

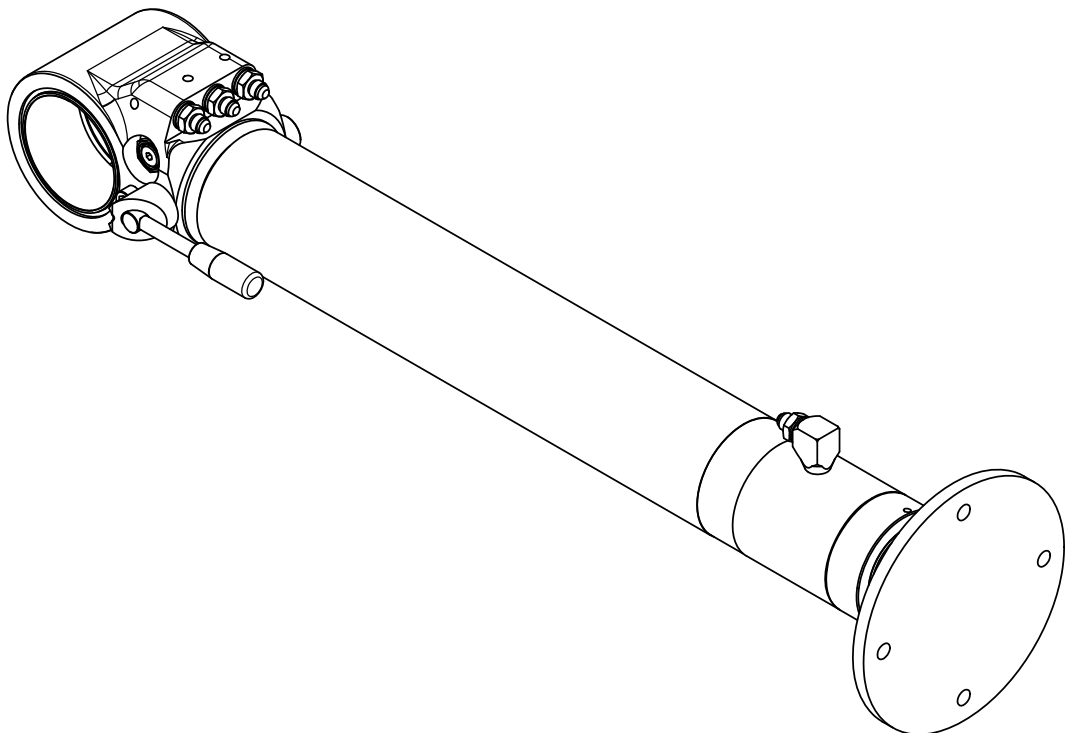
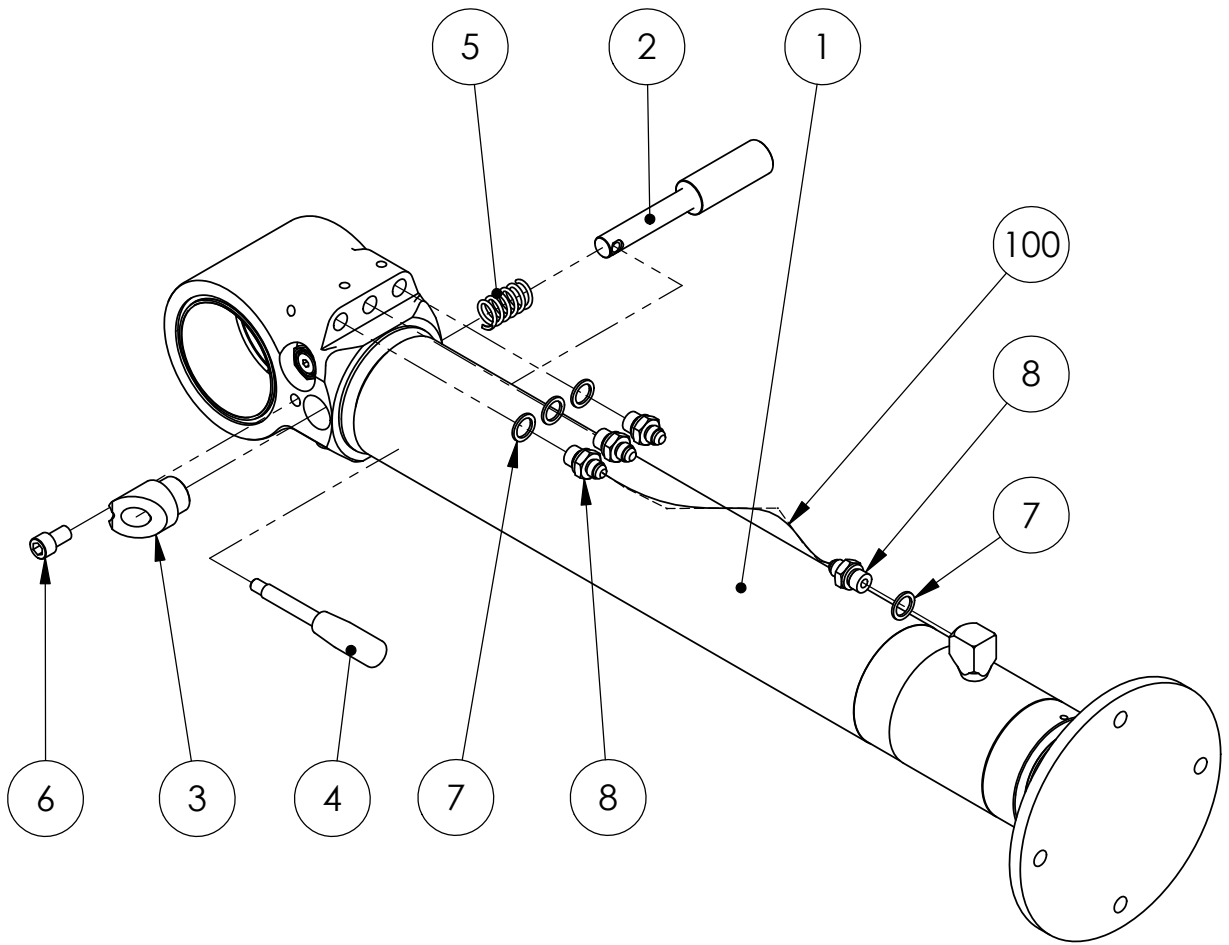

Item code	90025605	Revision	A
Title	STABILIZER	Date	18.06.2012
Specification	90/70X520 RIGHT ( FIXED FOOT )		

Pos	Item code	Title	Specification	Pc	Nto Weight
1	28942001	CYLINDER	90/70X520	1	57.69
2	90025017	SPINDLE	30/18-179	1	0.63
3	90025018	SLEEVE		1	0.26
4	3301574	LEVER	GN 310-12-125-E-NI M10	1	0.03
5	3300533	SPRING	18/45/7.6/6.88 -1643 SF-TF3	1	0.02
6	3010604	ALLEN SCREW	M12X20 8.8 DIN 912	1	0
7	3110040	USIT-SEAL	R-06 R 3/8"	4	0
8	3090901	CONNECTOR	6010-06-06	4	0.05
100	3132962	HYDRAULIC HOSE	A50005-06-06/241T-06/A50005-06-06/L=630/ TEX	1	0

90025606  
90/70x520 LEFT ( FIXED FOOT )

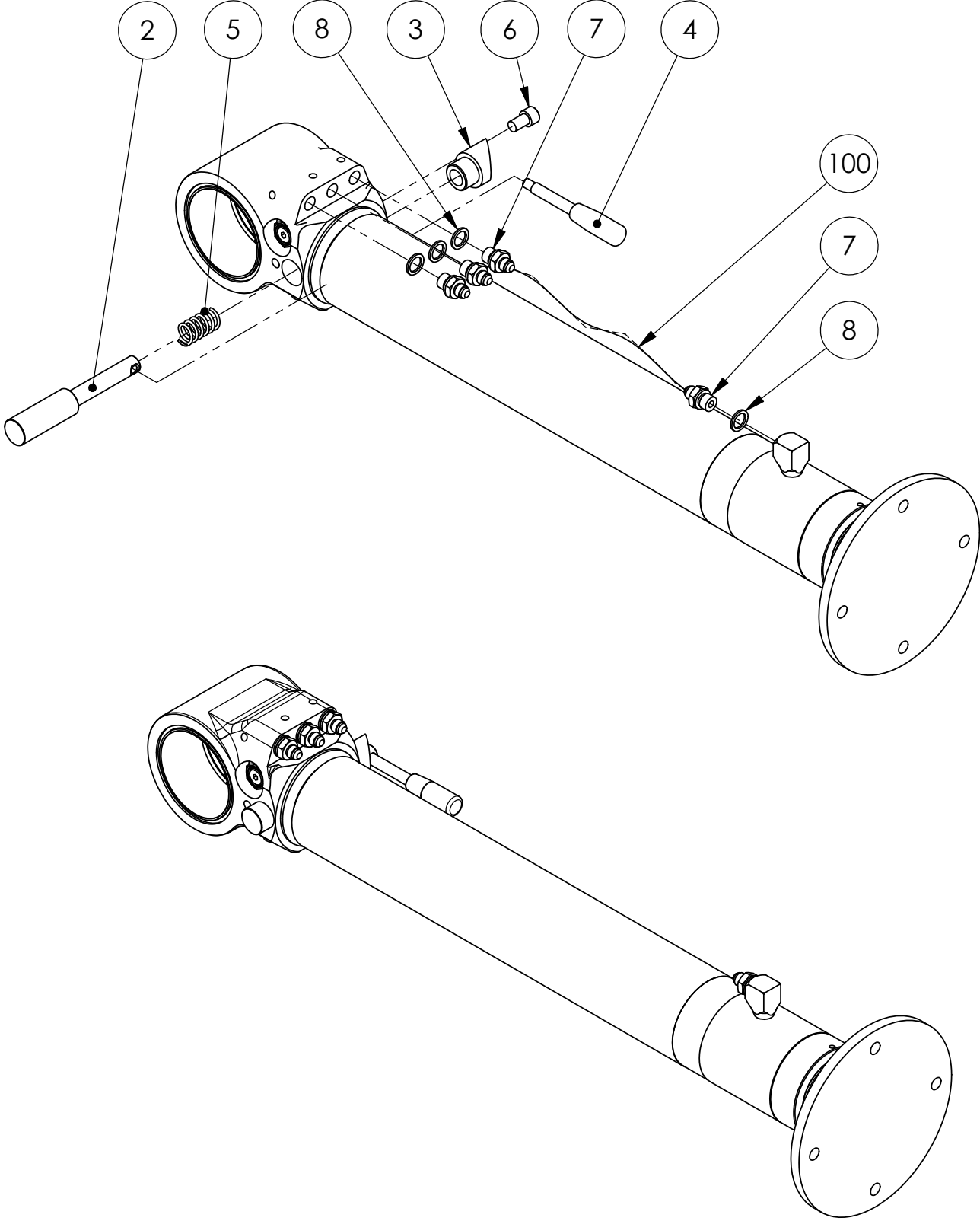

Item code	90025606	Revision	A
Title	STABILIZER	Date	18.06.2012
Specification	90/70X520 LEFT ( FIXED FOOT )		

Pos	Item code	Title	Specification	Pc	Nto Weight
1	28942001	CYLINDER	90/70X520	1	57.69
2	90025017	SPINDLE	30/18-179	1	0.63
3	90025018	SLEEVE		1	0.26
4	3301574	LEVER	GN 310-12-125-E-NI M10	1	0.03
5	3300533	SPRING	18/45/7.6/6.88 -1643 SF-TF3	1	0.02
6	3010604	ALLEN SCREW	M12X20 8.8 DIN 912	1	0
7	3090901	CONNECTOR	6010-06-06	4	0.05
8	3110040	USIT-SEAL	R-06 R 3/8"	4	0
100	3132962	HYDRAULIC HOSE	A50005-06-06/241T-06/A50005-06-06/L=630/ TEX	1	0

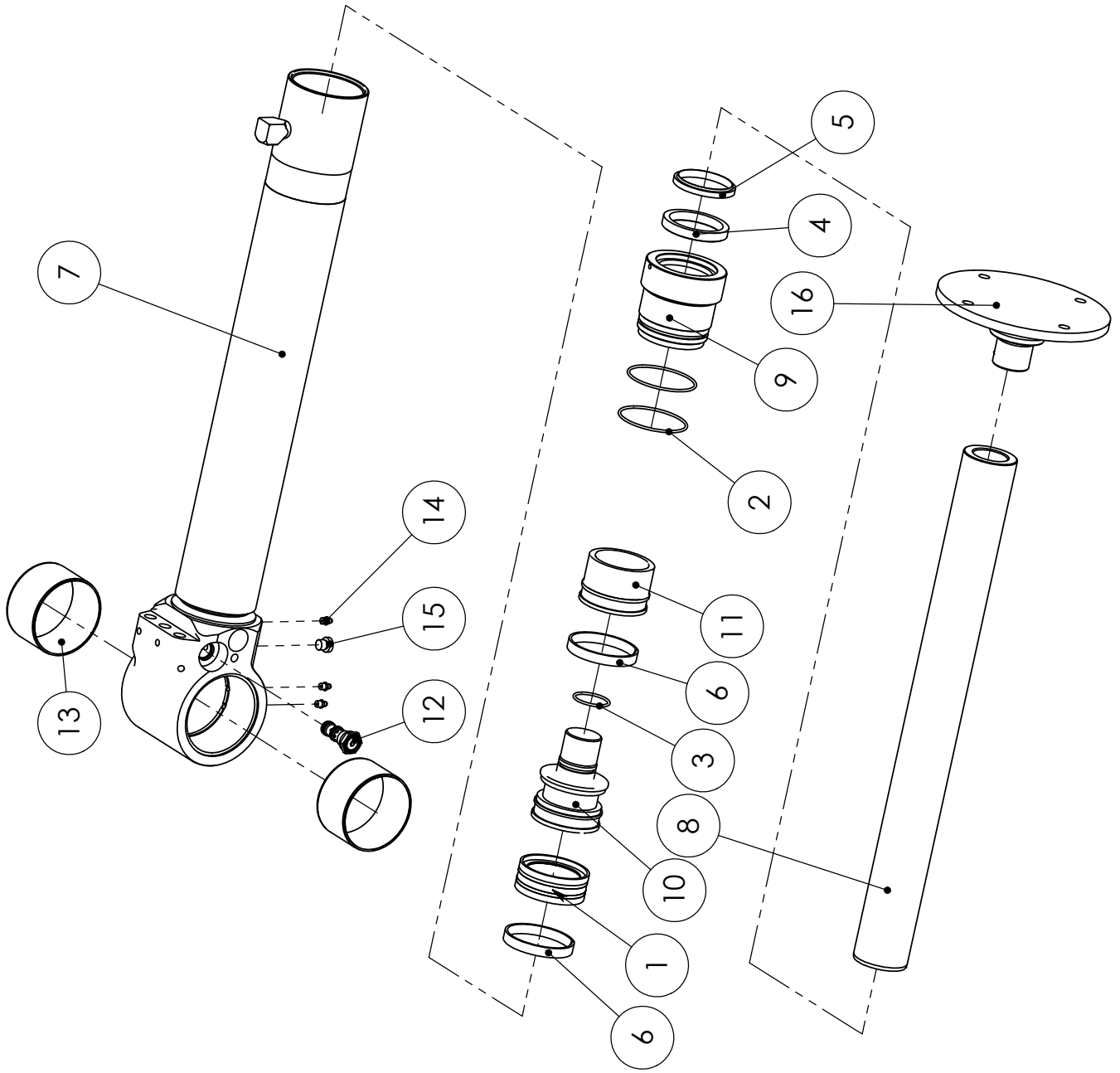

28942001





## SPARE PART LIST

Item code	28942001	Revision	-
Title	SYLINTERI	Date	30.11.2012
Specification	90/70X520		

Pos	Item code	Title	Specification	Dimensions	Pc	Amount	Unit	Nto Weight
1	3110025	MÄNNÄNTIIVISTE KOLV TÄTNIING PISTON SEAL KOLBENDICHTUNG	DAS 90/70X22		1			0.5
2	3110017	O-RENGAS O-RING O-RING O-RING	84.5X3 90 SHORE		2			0.02
3	3110258	O-RENGAS O-RING O-RING O-RING	42.2X3 90 SHORE		1			0.01
4	3110184	VARRENTIIVISTE KOLVSTÄNGSTÄTNIING ROD SEAL DICHTUNG FÜR KOLBENSTANGE	B 70/85X12 POLYPAC BALSELE		1			0.17
5	3110196	LUOVUJTIN AVSTRYKARE WIPER SEAL ABSTREIFER	GA 70/80X7/10		1			0.07
6	3110397	MÄNNÄNOHJAIN KOLV STYRNIING PISTON GUIDE KOLBENFÜHRUNG	E/PWR 90/84X13		2			0.08
7	28865101	SYLINTERIPUTKI CYLINDERROH R CYLINDER BARREL ZYLINDERROHR	90/70X500		1			30.74
8	28942302	MÄNNÄNVARSI KOLVSTÄNG PISTON ROD KOLBENSTANGE	70-693		1			13.17
9	28358202	OHJAIN STYRNIING GUIDANCE STEUERUNG	90/70		1			2.43
10	28942201	MÄNTÄ KOLV PISTON KOLBEN	90	L=122	1			2.46
11	28554105	HOLKKI HYLISA SLEEVE ACHSHALTER	ISKURAJOITINHOLKKI	L=62	1			0.96
12	3120843	VENTTIILI VENTIL VALVE VENTIL			1			0.13
13	3100344	LIUKULAAKERI BUSSNIING BUSHING GLEITLAGER	WB 802 10060		2			0.38
14	3050003	RASVANIPPA SMÖRJNIIPPEL GREASE NIPPLE SCHMIERNIPPEL	M8X1,25 DIN 71412		3			0
15	3090211	TULPPA PLUGG PLUG DECKEL			1			0.02
16	28942106	ANTURA BOTTEN BASE UNTERLAGE	TUKIJALKA		1			6.07
1-6	3111025	TIIVISTESARJA TÄTNIINGSSATS SEAL KIT DICHTUNGSSATZ	90/70		1			

90025608  
90/70x520 RIGHT ( ADJUSTABLE FOOT )

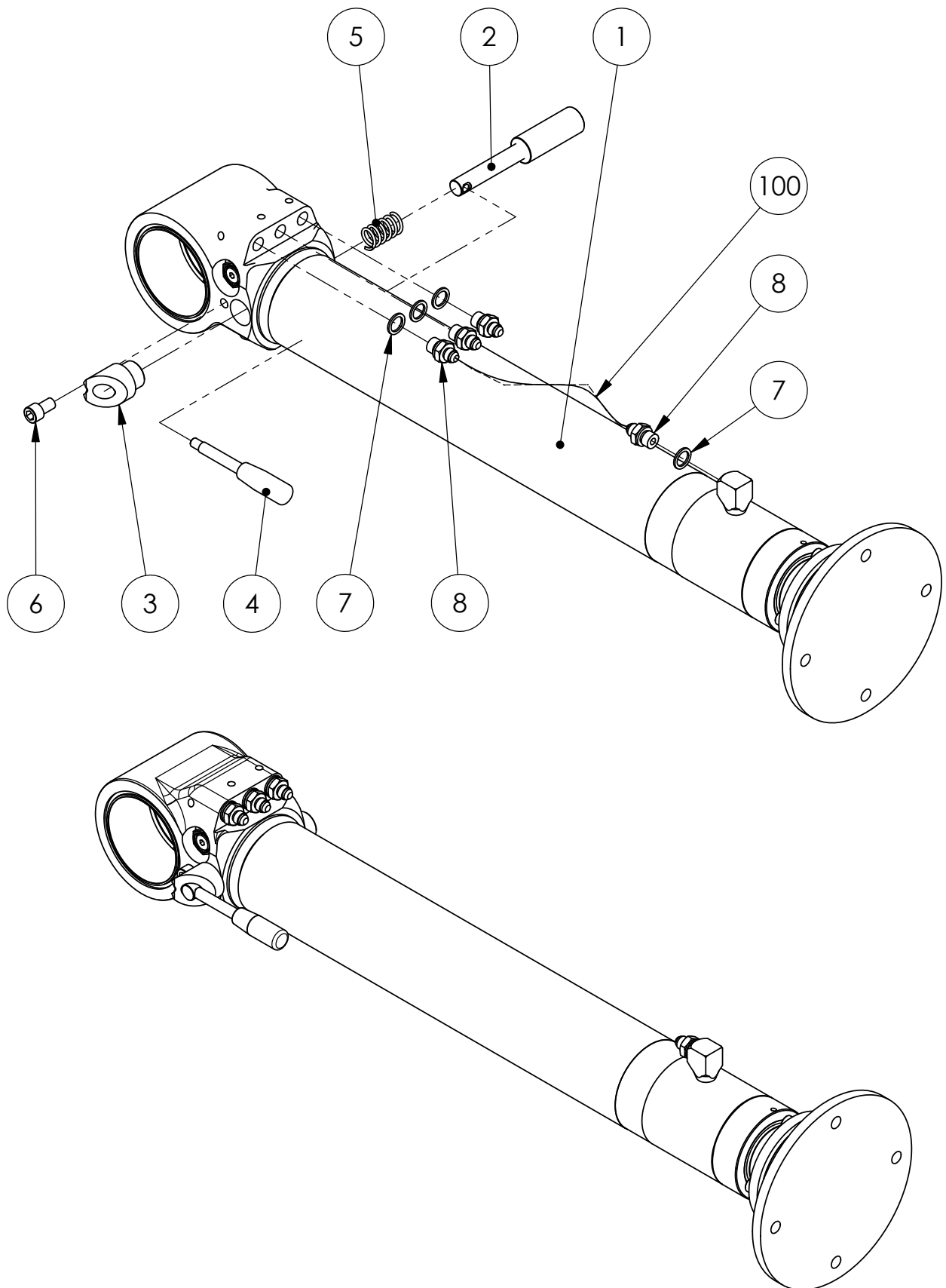

Item code	90025608	Revision	A
Title	STABILIZER	Date	19.06.2012
Specification	90/70X520 RIGHT ( ADJUSTABLE FOOT )		

Pos	Item code	Title	Specification	Pc	Nto Weight
1	28944001	CYLINDER	90/70X520	1	61.28
2	90025017	SPINDLE	30/18-179	1	0.63
3	90025018	SLEEVE		1	0.26
4	3301574	LEVER	GN 310-12-125-E-NI M10	1	0.03
5	3300533	SPRING	18/45/7.6/6.88 -1643 SF-TF3	1	0.02
6	3010604	ALLEN SCREW	M12X20 8.8 DIN 912	1	0
7	3110040	USIT-SEAL	R-06 R 3/8"	4	0
8	3090901	CONNECTOR	6010-06-06	4	0.05
100	3132962	HYDRAULIC HOSE	A50005-06-06/241T-06/A50005-06-06/L=630/ TEX	1	0

90025609  
90/70x520 LEFT ( ADJUSTABLE FOOT )

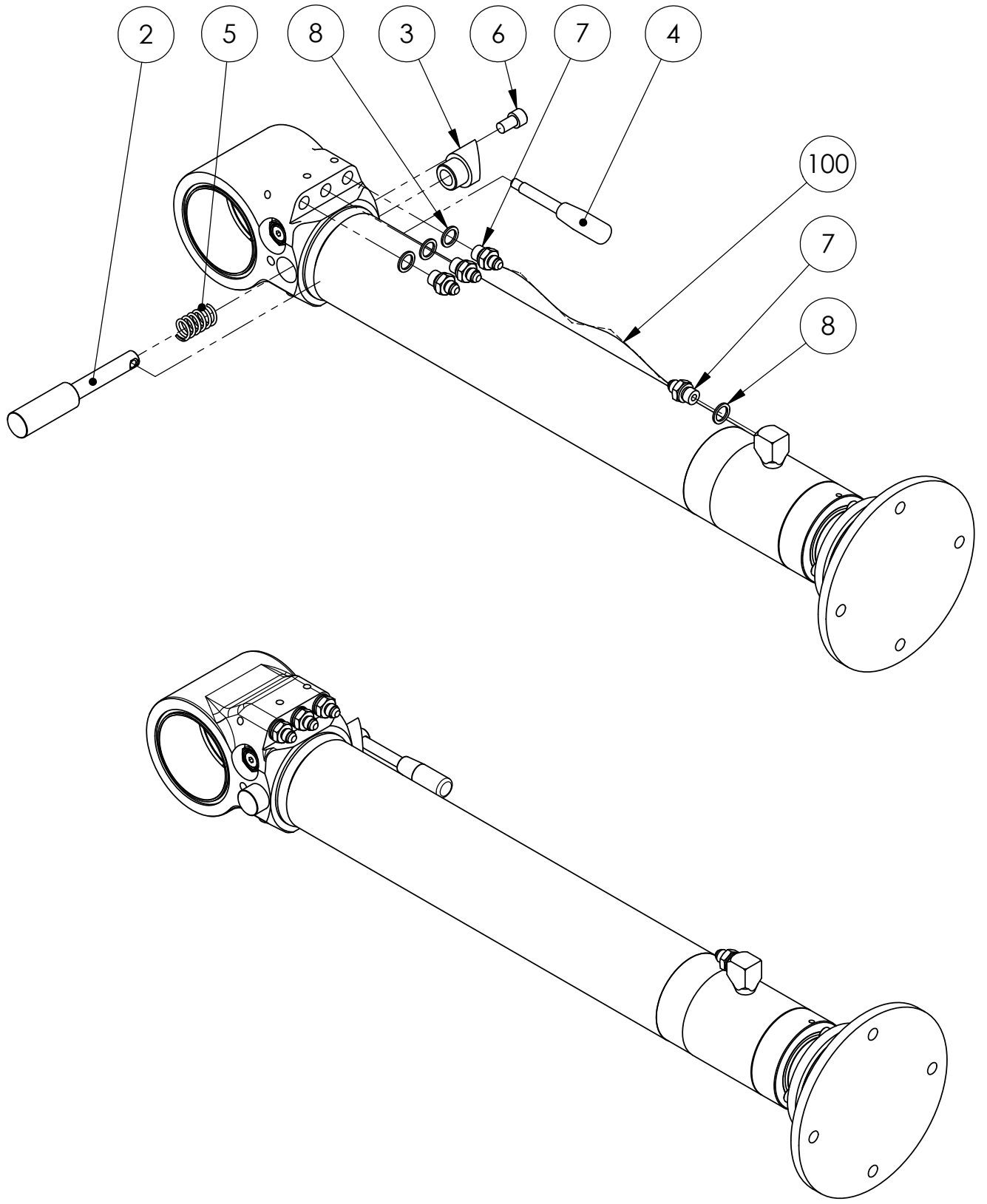

Item code	90025609	Revision	A
Title	STABILIZER	Date	19.06.2012
Specification	90/70X520 LEFT ( ADJUSTABLE FOOT )		

Pos	Item code	Title	Specification	Pc	Nto Weight
1	28944001	CYLINDER	90/70X520	1	61.28
2	90025017	SPINDLE	30/18-179	1	0.63
3	90025018	SLEEVE		1	0.26
4	3301574	LEVER	GN 310-12-125-E-NI M10	1	0.03
5	3300533	SPRING	18/45/7.6/6.88 -1643 SF-TF3	1	0.02
6	3010604	ALLEN SCREW	M12X20 8.8 DIN 912	1	0
7	3090901	CONNECTOR	6010-06-06	4	0.05
8	3110040	USIT-SEAL	R-06 R 3/8"	4	0
100	3132962	HYDRAULIC HOSE	A50005-06-06/241T-06/A50005-06-06/L=630/ TEX	1	0

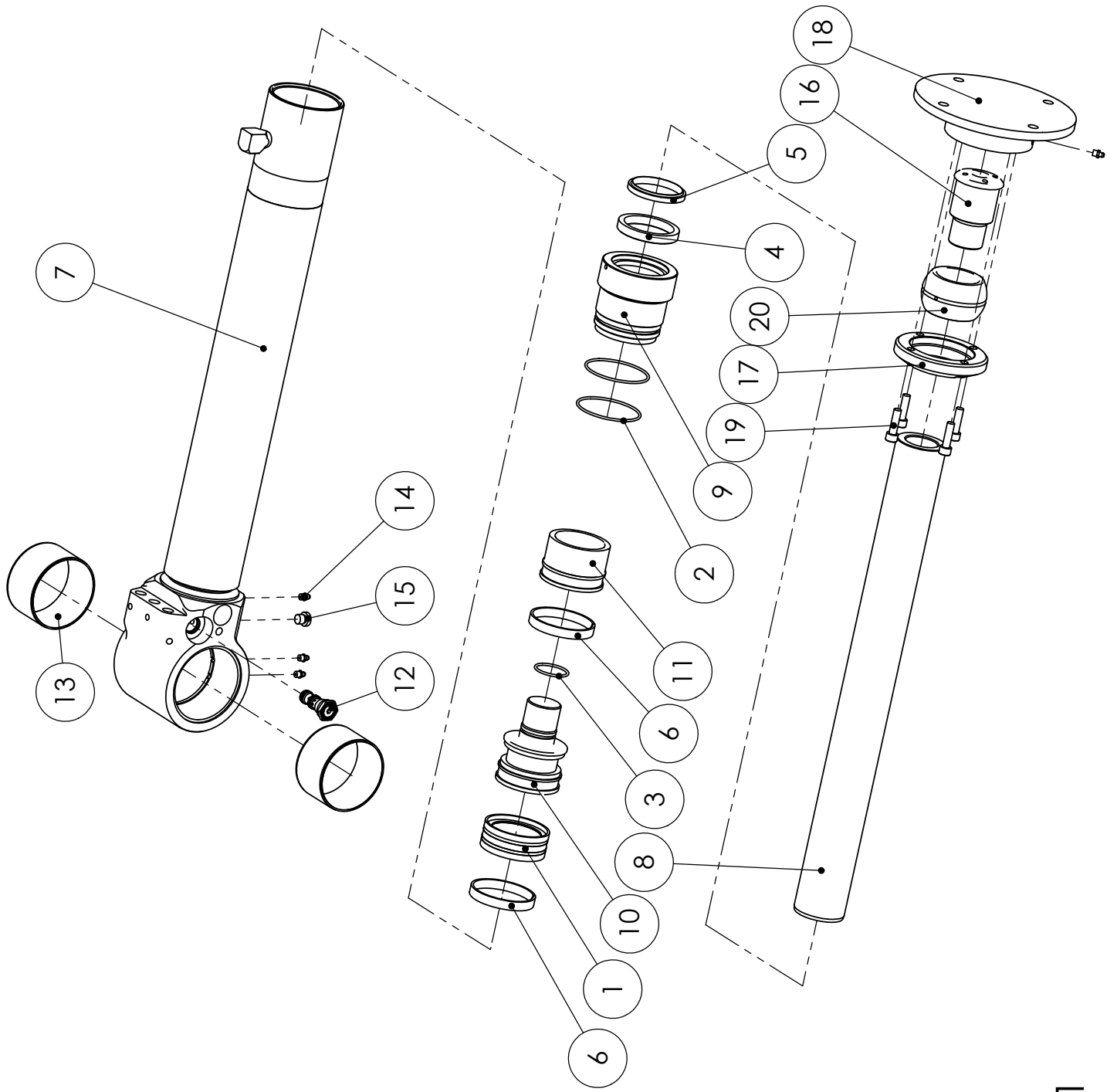

28944001



## SPARE PART LIST

Item code	28944001	Revision	-
Title	SYLINTERI	Date	30.11.2012
Specification	90/70X520		

Pos	Item code	Title	Specification	Dimensions	Pc	Amount	Unit	Nto Weight
1	3110025	MÄNNÄNTIIVISTE KOLV TÄTNIING PISTON SEAL KOLBENDICHTUNG	DAS 90/70X22		1			0.5
2	3110017	O-RENGAS O-RING O-RING O-RING	84.5X3 90 SHORE		2			0.02
3	3110258	O-RENGAS O-RING O-RING O-RING	42.2X3 90 SHORE		1			0.01
4	3110184	VARRENTIIVISTE KOLVSTÄNGSTÄTNIING ROD SEAL DICHTUNG FÜR KOLBENSTANGE	B 70/85X12 POLYPAC BALSELE		1			0.17
5	3110196	LUOVUJTIIN AVSTRYKARE WIPER SEAL ABSTREIFER	GA 70/80X7/10		1			0.07
6	3110397	MÄNNÄNOHJAIN KOLV STYRNIING PISTON GUIDE KOLBENFÜHRUNG	E/PWR 90/84X13		2			0.08
7	28865101	SYLINTERIPUTKI CYLINDERROH R CYLINDER BARREL ZYLINDERROHR	90/70X500		1			30.74
8	28942302	MÄNNÄNVARSI KOLVSTÄNG PISTON ROD KOLBENSTANGE	70-693		1			13.17
9	28358202	OHJAIN STYRNIING GUIDANCE STEUERUNG	90/70		1			2.43
10	28942201	MÄNTÄ KOLV PISTON KOLBEN	90	L=122	1			2.46
11	28554105	HOLKKI HYLISA SLEEVE ACHSHALTER	ISKURAJOITINHOLKKI	L=62	1			0.96
12	3120843	VENTTIILI VENTIL VALVE VENTIL			1			0.13
13	3100344	LIUKULAAKERI BUSSNIING BUSHING GLEITLAGER	WB 802 10060		2			0.38
14	3050003	RASVANIPPA SMÖRJNIIPPEL GREASE NIPPLE SCHMIERNIPPEL	M8X1.25 DIN 71412		4			0
15	3090211	TULPPA PLUGG PLUG DECKEL			1			0.02
16	28944401	AKSELI AXEL AXLE AXHSE	60/M47	L=105	1			1.9
17	28861107	KANSI DÄCK COVER DECKEL		L=28	1			1.07
18	28861106	ANTURA BOTTEN BASE UNTERLAGE			1			5.55
19	3010970	KUUSIOKOLORUUVI INSEKSKRUUV ALLEN SCREW INNENSECHSKANTSCHEHRAUBE	M10X35 12.9 DIN 912		4			0
20	3100428	LAAKERI LAGER BEARING LAGER	NIVELLAAKERIN PALLO GEF 60 ES	L=56	1			1.14
1-6	3111025	TIIVISTESARJA TÄTNIINGSSATS SEAL KIT DICHTUNGSSATZ	90/70		1			

90025610  
90/70x620 RIGHT ( ADJUSTABLE FOOT )

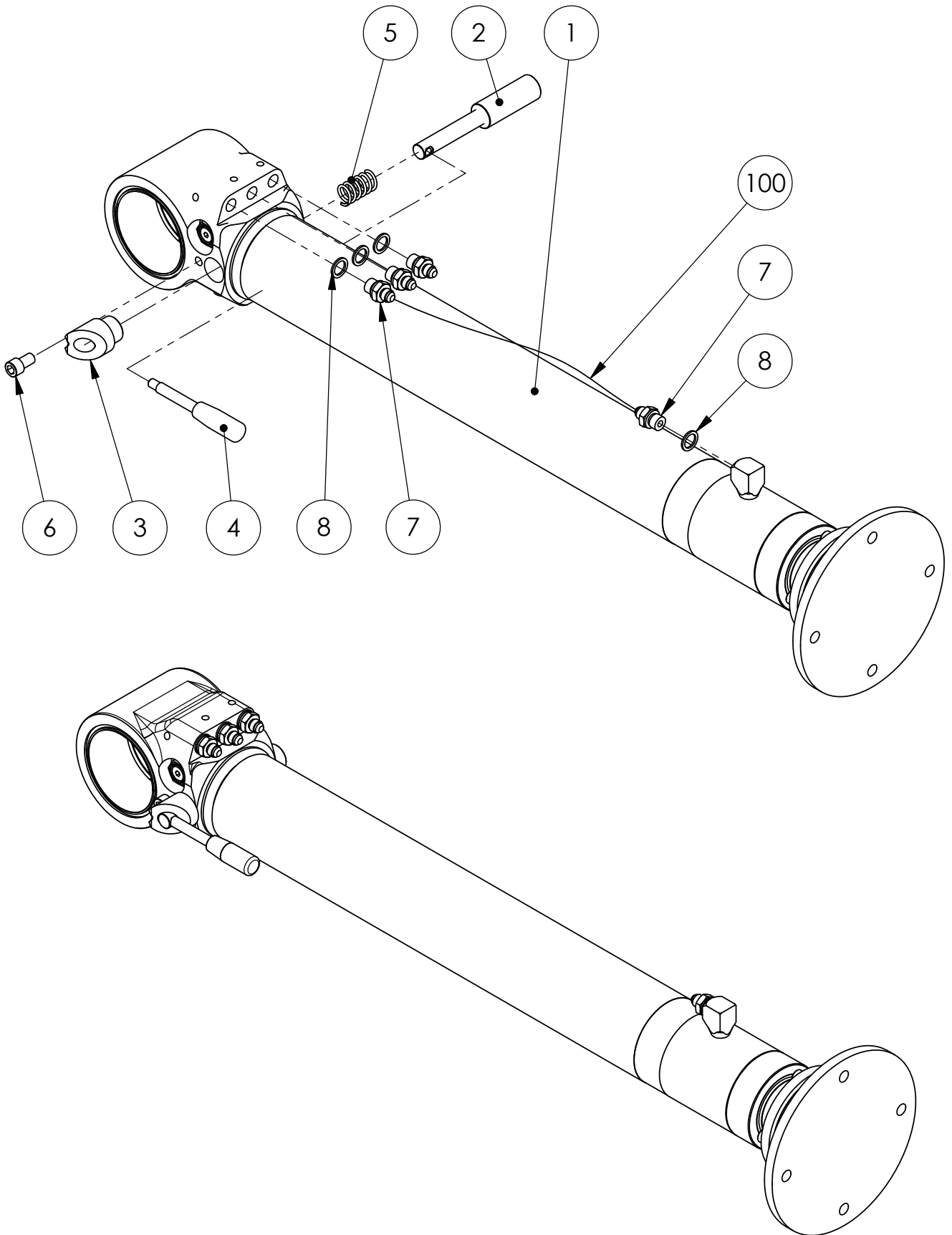



Item code	90025610	Revision	A
Title	STABILIZER	Date	19.06.2012
Specification	90/70X620 RIGHT ( ADJUSTABLE FOOT )		

Pos	Item code	Title	Specification	Pc	Nto Weight
1	28945001	CYLINDER	90/70X620	1	65.02
2	90025017	SPINDLE	30/18-179	1	0.63
3	90025018	SLEEVE		1	0.26
4	3301574	LEVER	GN 310-12-125-E-NI M10	1	0.03
5	3300533	SPRING	18/45/7.6/6.88 -1643 SF-TF3	1	0.02
6	3010604	ALLEN SCREW	M12X20 8.8 DIN 912	1	0
7	3090901	CONNECTOR	6010-06-06	4	0.05
8	3110040	USIT-SEAL	R-06 R 3/8"	4	0
100	3132961	HYDRAULIC HOSE	A50005-06-06/241T-06/A50005-06-06S/L=730/TEX	1	

90025611

90/70x620 LEFT ( ADJUSTABLE FOOT )

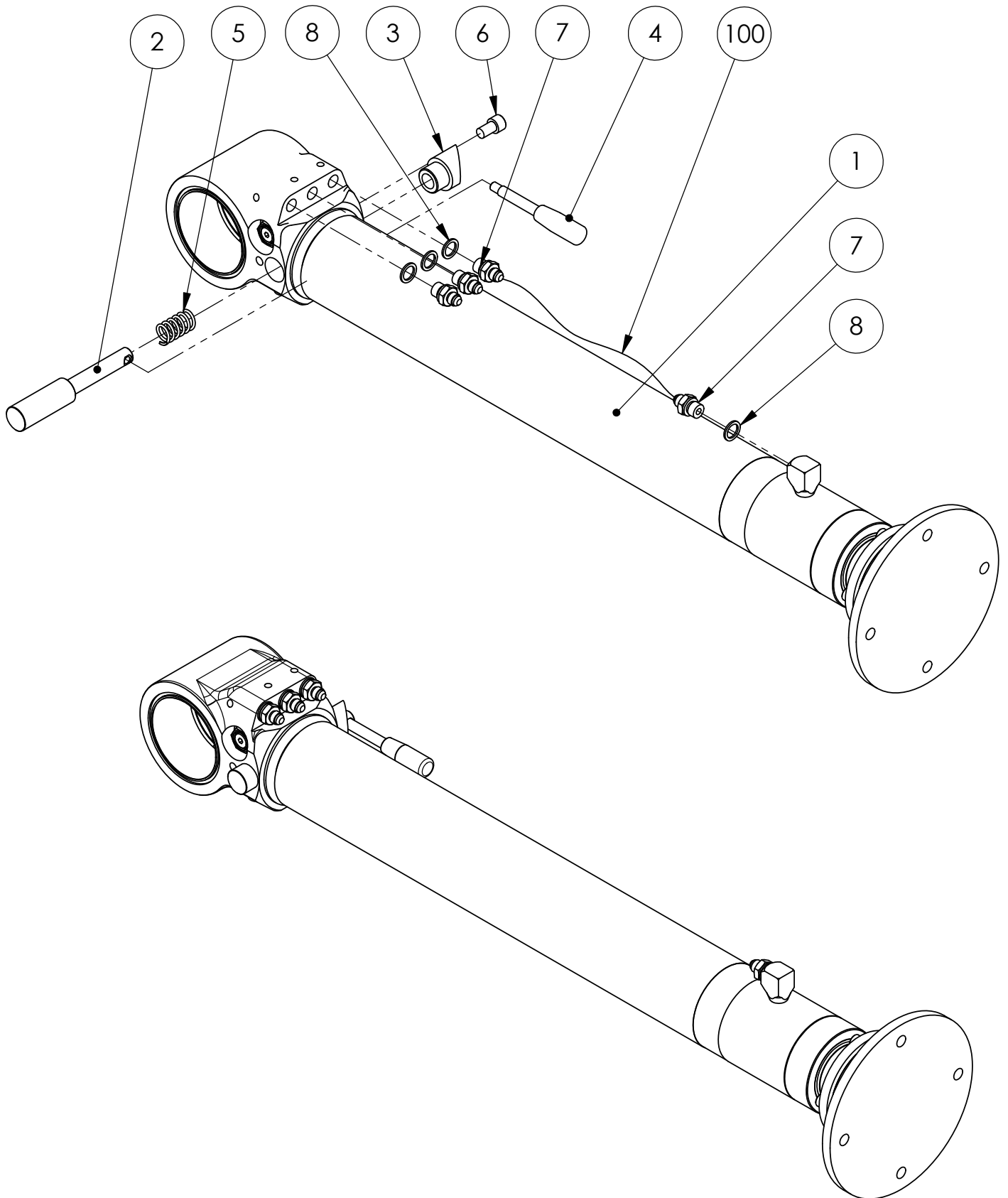

Item code	90025611	Revision	A
Title	STABILIZER	Date	19.06.2012
Specification	90/70X620 LEFT ( ADJUSTABLE FOOT )		

Pos	Item code	Title	Specification	Pc	Nto Weight
1	28945001	CYLINDER	90/70X620	1	65.02
2	90025017	SPINDLE	30/18-179	1	0.63
3	90025018	SLEEVE		1	0.26
4	3301574	LEVER	GN 310-12-125-E-NI M10	1	0.03
5	3300533	SPRING	18/45/7.6/6.88 -1643 SF-TF3	1	0.02
6	3010604	ALLEN SCREW	M12X20 8.8 DIN 912	1	0
7	3090901	CONNECTOR	6010-06-06	4	0.05
8	3110040	USIT-SEAL	R-06 R 3/8"	4	0
100	3132961	HYDRAULIC HOSE	A50005-06-06/241T-06/A50005-06-06S/L=730/TEX	1	

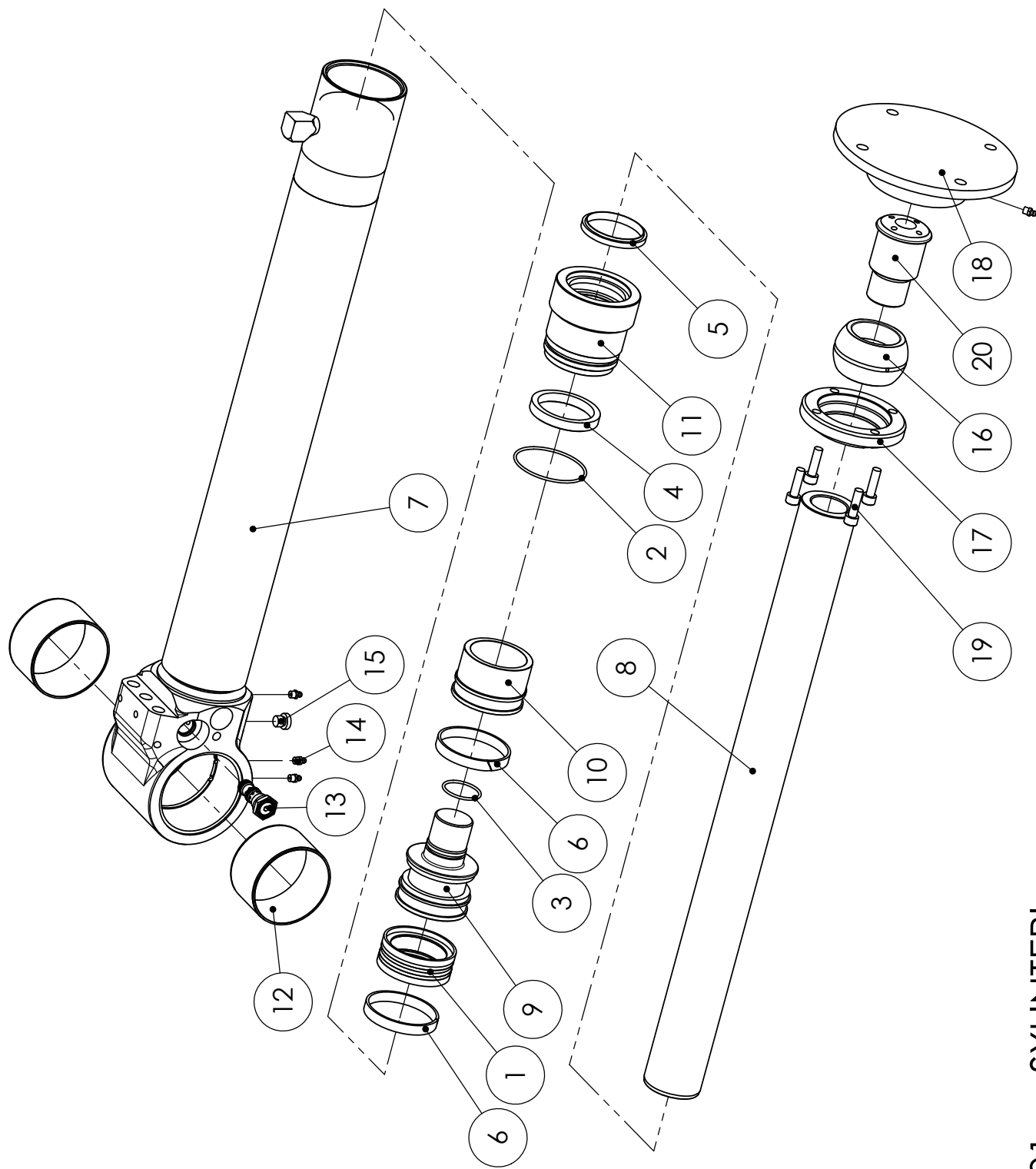

28945001 SYLINTERI

VARAOSAT \ RESERVDLAR \ SPARE PARTS \ ERSATZTEIL



## SPARE PART LIST

Item code	28945001	Revision	-
Title	SYLINTERI	Date	15.01.2013
Specification	90/70X620		

Pos	Item code	Title	Specification	Dimensions	Pc	Amount	Unit	Nto Weight
1	3110025	MÄNNÄNTIIVISTE KOLV TÄTNIING PISTON SEAL KOLBENDICHTUNG	DAS 90/70X22		1			0.5
2	3110017	O-RENGAS O-RING O-RING O-RING	84.5X3 90 SHORE		2			0.02
3	3110258	O-RENGAS O-RING O-RING O-RING	42.2X3 90 SHORE		1			0.01
4	3110184	VARRENTIIVISTE KOLVSTÄNGSTÄTNIING ROD SEAL DICHTUNG FÜR KOLBENSTANGE	B 70/85X12 POLYPAC BALSELE		1			0.17
5	3110196	LUOVUJIN AVSTRYKARE WIPER SEAL ABSTREIFER	GA 70/80X7/10		1			0.07
6	3110397	MÄNNÄNOHJAIN KOLV STYRNING PISTON GUIDE KOLBENFÜHRUNG	E/PWR 90/84X13		2			0.08
7	28861101	SYLINTERIPUTKI CYLINDER BARREL ZYLINDERROHR	90/70X600		1			32.54
8	28943302	MÄNNÄNVARSI KOLVSTÄNG PISTON ROD KOLBENSTANGE	70-793		1			15.11
9	28942201	MÄNTÄ KOLV PISTON KOLBEN	90	L=122	1			2.46
10	28554105	HOLKKI HYLSA SLEEVE ACHSHALTER	ISKURAJOITINHOLKKI	L=62	1			0.96
11	28358202	OHJAIN STYRNING GUIDANCE STEUERUNG	90/70		1			2.43
12	3100344	LIUKULAAKERI BUSSNING BUSHING GLEITLAGER	WB 802 10060		2			0.38
13	3120843	VENTTIILI VALVE VALVE			1			0.13
14	3050003	RASVANIPPA SMÖRNIPPPEL GREASE NIPPLE SCHMIERNIPPEL	M8X1,25 DIN 71412		4			0
15	3090211	TULPPA PLUGG PLUG DECKEL			1			0.02
16	3100428	LAAKERI LAGER BEARING LAGER		L=56	1			1.14
17	28861107	KANSI DÄCK COVER DECKEL	NIVELLAAKERIN PALLO GEF 60 ES	L=28	1			1.07
18	28861106	ANTURA BOTTEN BASE UNTERLAGE			1			5.55
19	3010970	KUUSIOKOLORUUVI INSEKSRUUVI ALLEN SCREW INNENSECHSKANTSCHEIBE	M10X35 12.9 DIN 912		4			0
20	28944401	AKSELI AXEL AXLE ACHSE	60/M47	L=105	1			1.9
1-6	3111025	TIIVISTESARJA TÄTNIINGSSATS SEAL KIT DICHTUNGSSATZ	90/70		1			

90025527

2109Z, 2110Z L=3320 RIGHT

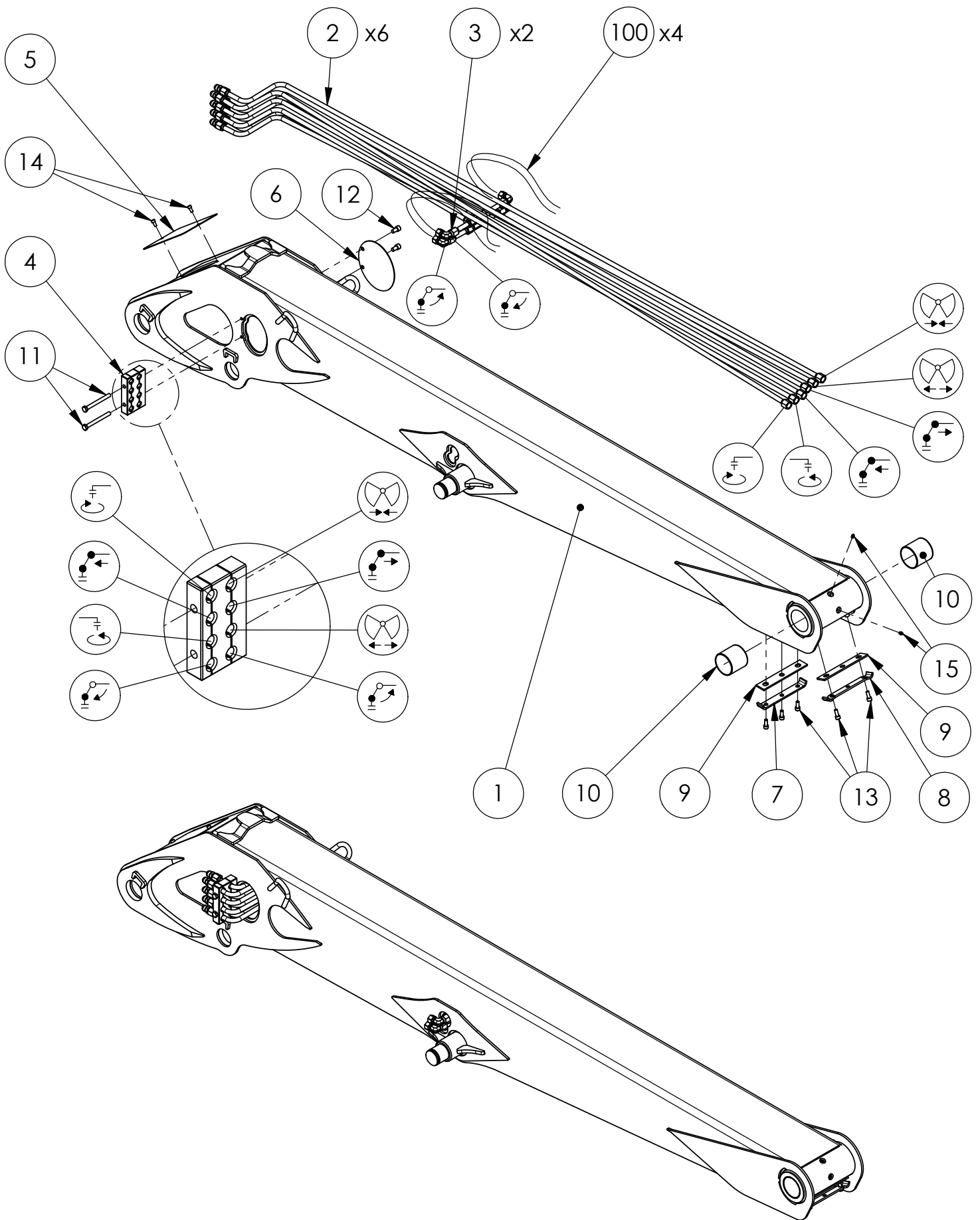

Item code	90025527	Revision	-
Title	LIFT BOOM	Date	25.05.2012
Specification	3320 RIGHT VAR		

Pos	Item code	Title	Specification	Pc	Nto Weight
1	90025505	LIFT BOOM	3320 HITS+KON	1	238.74
2	90024762	HYDRAULIC PIPE	1 KOK	6	2.25
3	90024764	HYDRAULIC PIPE	SIIRTOSYL KOK	2	2.67
4	90024321	FASTENER	D = 16	1	1.01
5	90023441	COVER		1	0.76
6	90025045	COVER		1	0.44
7	90013744	FASTENER		1	0.32
8	90015473	FASTENER		1	0.32
9	90013489	RUBBER	5X40X220	2	0.06
10	3100187	BUSHING	WB 802 8080	2	0.41
11	3010122	HEW SCREW	M12X120 8.8 ZN DIN 931	2	0
12	3010604	ALLEN SCREW	M12X20 8.8 DIN 912	2	0
13	3010685	ALLEN SCREW	M10X25 8.8 ZN DIN 912	5	0
14	3010292	ALLEN SCREW	M8X16 8.8 ZN DIN 912	2	0
15	3050003	GREASE NIPPLE	M8X1,25 DIN 71412	2	0
100	3132975	HYDRAULIC HOSE	A50005-10-08/241T-08/500200-10-08/L=750	4	

90025636

2109Z, 2110Z L=3520 RIGHT

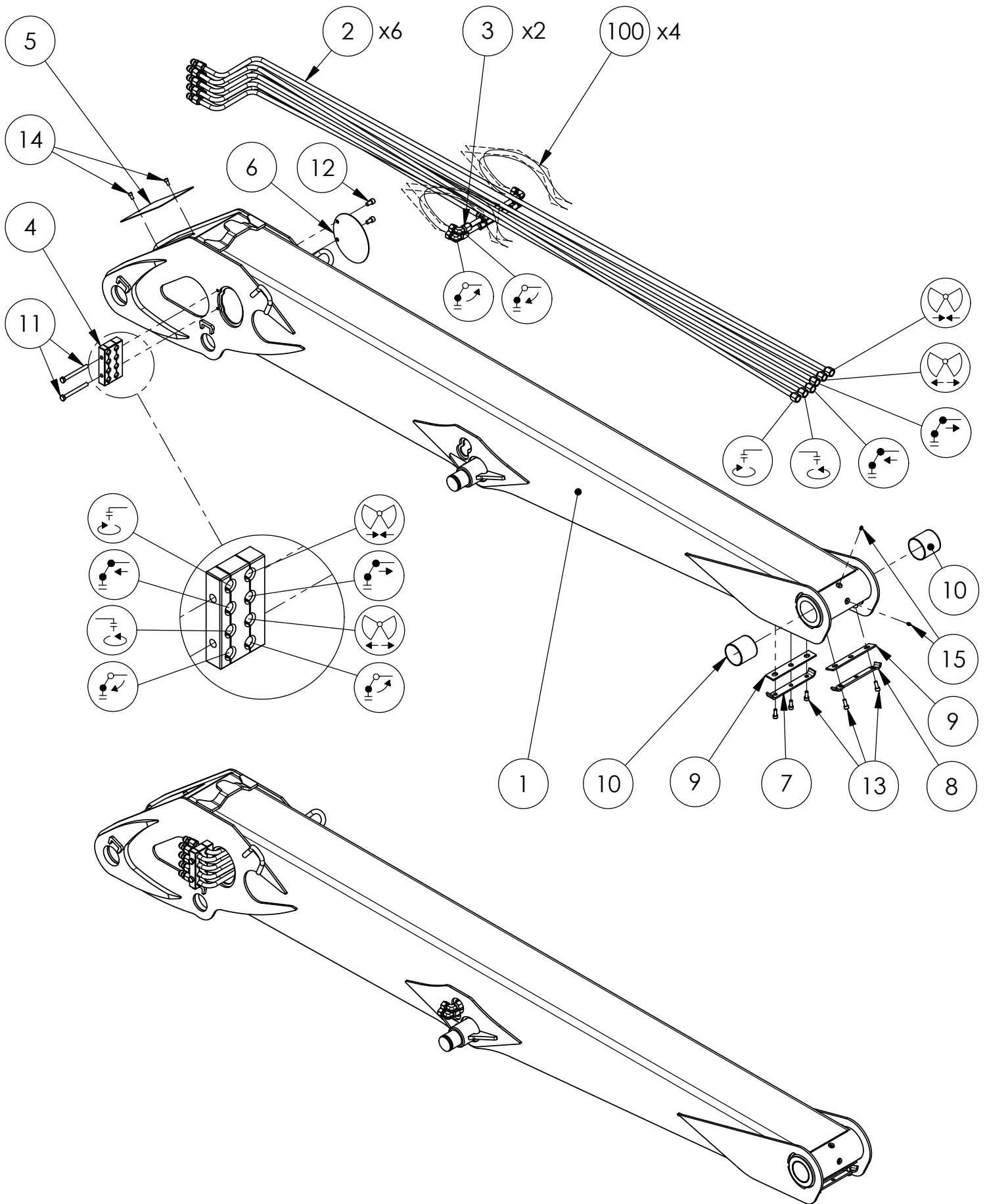



Item code	90025636	Revision	-
Title	LIFT BOOM	Date	02.07.2012
Specification	3520 RIGHT VAR		

Pos	Item code	Title	Specification	Pc	Nto Weight
1	90025633	LIFT BOOM	L=3520 HITS+KON	1	247.87
2	90025637	HYDRAULIC PIPE	1 KOK	6	2.38
3	90025639	HYDRAULIC PIPE	SIIRTOSYL KOK	2	2.8
4	90024321	FASTENER	D = 16	1	1.01
5	90023441	COVER		1	0.76
6	90025045	COVER		1	0.44
7	90013744	FASTENER		1	0.32
8	90015473	FASTENER		1	0.32
9	90013489	RUBBER	5X40X220	2	0.06
10	3100187	BUSHING	WB 802 8080	2	0.41
11	3010122	HEW SCREW	M12X120 8.8 ZN DIN 931	2	0
12	3010604	ALLEN SCREW	M12X20 8.8 DIN 912	2	0
13	3010685	ALLEN SCREW	M10X25 8.8 ZN DIN 912	5	0
14	3010292	ALLEN SCREW	M8X16 8.8 ZN DIN 912	2	0
15	3050003	GREASE NIPPLE	M8X1,25 DIN 71412	2	0
100	3132975	HYDRAULIC HOSE	A50005-10-08/241T-08/500200-10-08/L=750	4	

90025650  
L = 4700

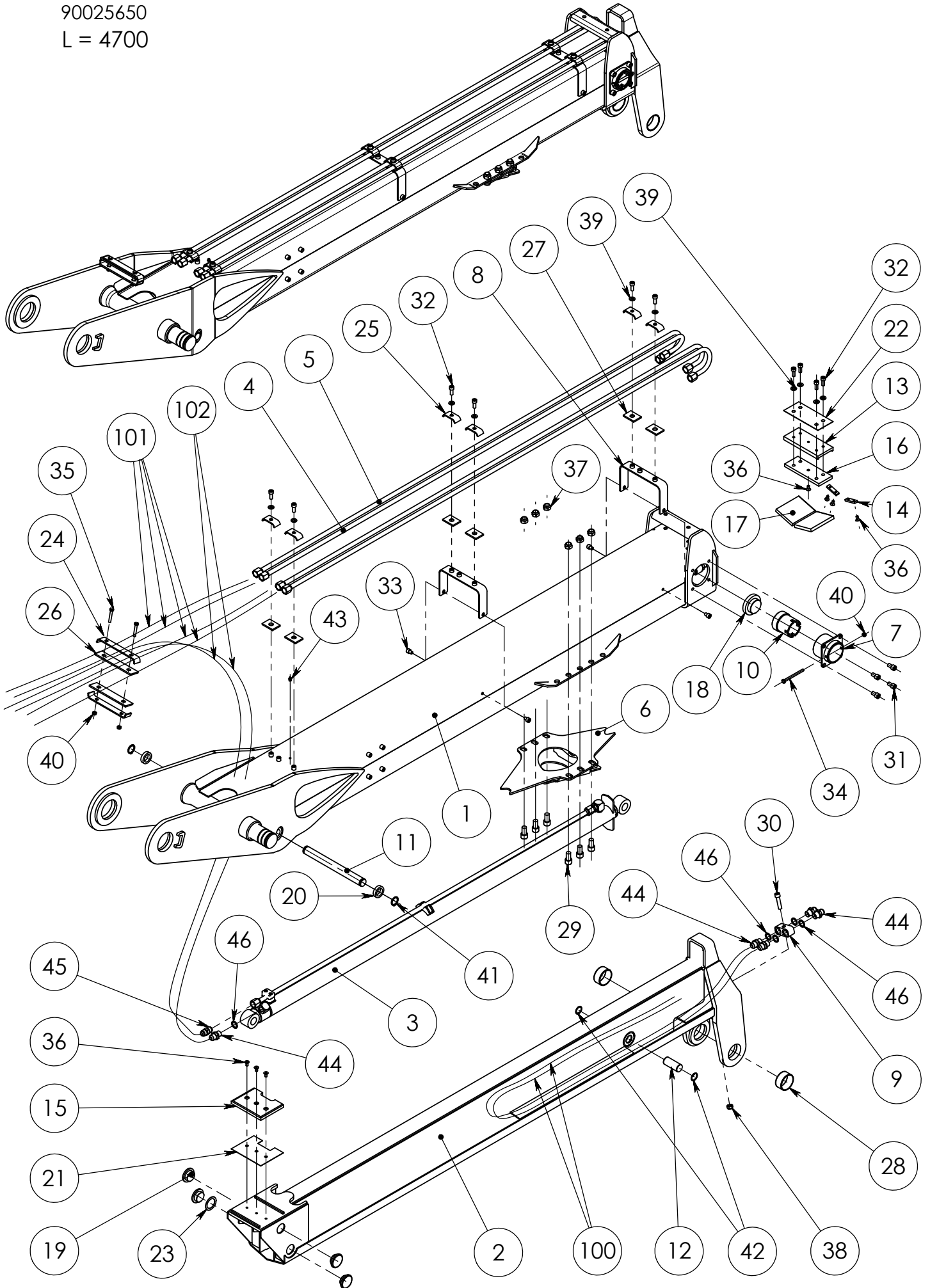

Item code	90025650	Revision	A
Title	OUTER BOOM	Date	05.07.2012
Specification	L=4700 1-JATK		

Pos	Item code	Title	Specification	Pc	Nto Weight
1	90025651	OUTER BOOM	L=2945 HITS+ KON	1	149.74
2	90025760	EXTENSION	L=2475 HITS+KON	1	92.18
3	90021354	CYLINDER	50/30 X 1650	1	28.91
4	90021405	PIPE	L=2324 KOK	2	1.75
5	90021407	PIPE	L=2365 KOK	2	1.77
6	90021531	RACK	HITS	1	6.75
7	90021394	FASTENER	HITS	2	1.31
8	90025766	FASTENER	L=204 HITS	2	0.55
9	90021408	CONNECTOR	R 1/2"	2	0.35
10	90021396	FASTENER		2	0.85
11	90018765	AXLE	30-304	1	1.68
12	90022463	AXLE	30-71	1	0.39
13	90020556	FASTENER	L-180	1	1.18
14	90010345	HOLDER		2	0.03
15	90014887	GLIDE PAD	120X155	1	0.24
16	90020563	GLIDE PAD	70X180	1	0.17
17	90014768	GLIDE PAD	12 X 90 X 120	2	0.15
18	90021397	GLIDE PAD	56X80-15X15	2	0.13
19	90011001	GLIDE PAD	D=55-19/7	4	0.03
20	90025804	SLEEVE	40/31-11	2	0.01
21	90017085	PLATE	119X155	1	0.13
22	90020567	PLATE	80X180	1	0.11
23	21039422	SHIM	1XD=55	1	0.01
24	90021958	FASTENER	4X30-215	2	0.2
25	90010442	FASTENER	LT4X30-72	6	0.07
26	90021961	RUBBER	5X40-190	2	0.05
27	90010443	RUBBER	5X55-40	6	0.01
28	3100225	BUSHING	WB 802 6030	2	0.11
29	3010700	ALLEN SCREW	M16X30 8.8 ZN DIN 912	6	0
30	3010580	ALLEN SCREW	M12X50 8.8 ZN DIN 912	2	0
31	3010604	ALLEN SCREW	M12X20 8.8 DIN 912	8	0
32	3010685	ALLEN SCREW	M10X25 8.8 ZN DIN 912	10	0
33	3010297	ALLEN SCREW	M10X12 8.8 ZN DIN 912	4	0
34	3010447	HEW SCREW	M8X100 8.8 ZN DIN 931	2	0
35	3010072	HEW SCREW	M8X50 8.8 ZN DIN 931	2	0
36	3010190	ALLEN SCREW	M8X16 10.9 DIN 7991	8	0

Item code	90025650	Revision	A
Title	OUTER BOOM	Date	05.07.2012
Specification	L=4700 1-JATK		

Pos	Item code	Title	Specification	Pc	Nto Weight
37	3020010	NUT	M16 ZN DIN 985	6	0.03
38	3020005	NUT	M12 ZN DIN 985	2	0.02
39	3030003	WASHER	M10/11 ZN DIN 126	10	0
40	3020001	NUT	M8 ZN DIN 985	4	0.01
41	3060092	SNAP RING	AS 30X2 ZN DIN 471	2	0
42	3060019	SNAP RING	30 DIN 472	2	0
43	3050003	GREASE NIPPLE	M8X1,25 DIN 71412	1	0
44	3090917	CONNECTOR (STRAIGHT)	26-040010810 R 1/2" -7/8" JIC	9	0.11
45	3090654	CONNECTOR	1010-10-10	1	0.09
46	3110042	USIT-SEAL	R-08 R 1/2"	9	0.01
100	3132972	HYDRAULIC HOSE	A50005-10-08/241X-08/500200-10-08/L=2200	4	0
101	3132973	HYDRAULIC HOSE	500200-10-08/241T-08/500200-10-08/L=1100	4	
102	3133073	HYDRAULIC HOSE	500200-10-08/241T-08/A50064-10-08/L=1100	2	

90025769  
L = 4620

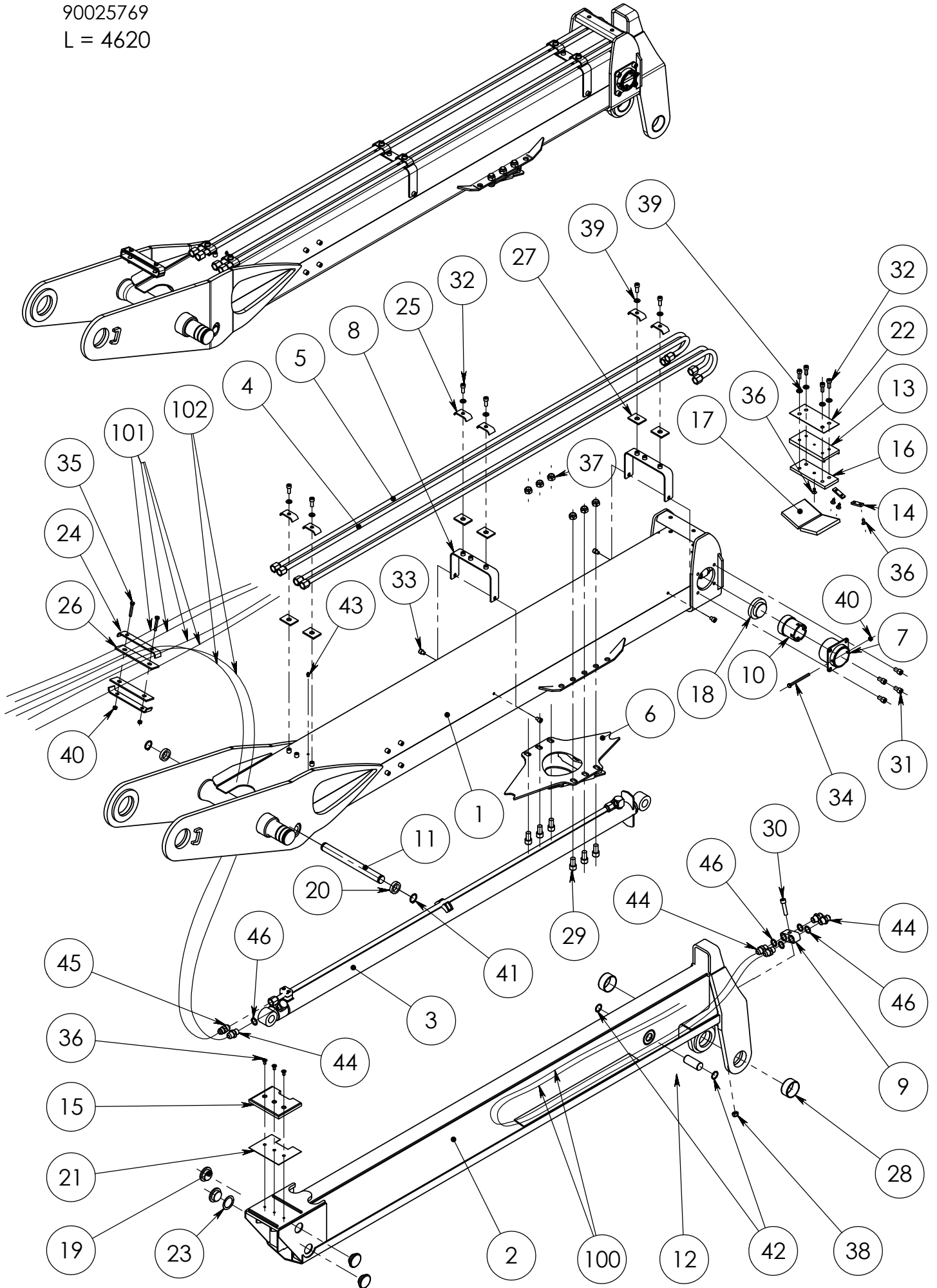

Item code	90025769	Revision	A
Title	OUTER BOOM	Date	26.09.2012
Specification	L=4620 1-JATK		

Pos	Item code	Title	Specification	Pc	Nto Weight
1	90025770	OUTER BOOM	L=2865 HITS+ KON	1	147.58
2	90025773	EXTENSION	L=2395 HITS+KON	1	90.01
3	90021354	CYLINDER	50/30 X 1650	1	28.91
4	90024897	PIPE	L= 2244 KOK	2	1.69
5	90024899	PIPE	L=2285 KOK	2	1.72
6	90021531	RACK	HITS	1	6.75
7	90021394	FASTENER	HITS	2	1.31
8	90025766	FASTENER	L=204 HITS	2	0.55
9	90021408	CONNECTOR	R 1/2"	2	0.35
10	90021396	FASTENER		2	0.85
11	90018765	AXLE	30-304	1	1.68
12	90022463	AXLE	30-71	1	0.39
13	90020556	FASTENER	L-180	1	1.18
14	90010345	HOLDER		2	0.03
15	90014887	GLIDE PAD	120X155	1	0.24
16	90020563	GLIDE PAD	70X180	1	0.17
17	90014768	GLIDE PAD	12 X 90 X 120	2	0.15
18	90021397	GLIDE PAD	56X80-15X15	2	0.13
19	90011001	GLIDE PAD	D=55-19/7	4	0.03
20	90025804	SLEEVE	40/31-11	2	0.01
21	90017085	PLATE	119X155	1	0.13
22	90020567	PLATE	80X180	1	0.11
23	21039422	SHIM	1XD=55	1	0.01
24	90021958	FASTENER	4X30-215	2	0.2
25	90010442	FASTENER	LT4X30-72	6	0.07
26	90021961	RUBBER	5X40-190	2	0.05
27	90010443	RUBBER	5X55-40	6	0.01
28	3100225	BUSHING	WB 802 6030	2	0.11
29	3010700	ALLEN SCREW	M16X30 8.8 ZN DIN 912	6	0
30	3010580	ALLEN SCREW	M12X50 8.8 ZN DIN 912	2	0
31	3010604	ALLEN SCREW	M12X20 8.8 DIN 912	8	0
32	3010685	ALLEN SCREW	M10X25 8.8 ZN DIN 912	10	0
33	3010297	ALLEN SCREW	M10X12 8.8 ZN DIN 912	4	0
34	3010447	HEW SCREW	M8X100 8.8 ZN DIN 931	2	0
35	3010072	HEW SCREW	M8X50 8.8 ZN DIN 931	2	0
36	3010190	ALLEN SCREW	M8X16 10.9 DIN 7991	8	0

Item code	90025769	Revision	A
Title	OUTER BOOM	Date	26.09.2012
Specification	L=4620 1-JATK		

Pos	Item code	Title	Specification	Pc	Nto Weight
37	3020010	NUT	M16 ZN DIN 985	6	0.03
38	3020005	NUT	M12 ZN DIN 985	2	0.02
39	3030003	WASHER	M10/11 ZN DIN 126	10	0
40	3020001	NUT	M8 ZN DIN 985	4	0.01
41	3060092	SNAP RING	AS 30X2 ZN DIN 471	2	0
42	3060019	SNAP RING	30 DIN 472	2	0
43	3050003	GREASE NIPPLE	M8X1,25 DIN 71412	1	0
44	3090917	CONNECTOR (STRAIGHT)	26-040010810 R 1/2" -7/8" JIC	9	0.11
45	3090654	CONNECTOR	1010-10-10	1	0.09
46	3110042	USIT-SEAL	R-08 R 1/2"	9	0.01
100	3132972	HYDRAULIC HOSE	A50005-10-08/241X-08/500200-10-08/L=2200	4	0
101	3132973	HYDRAULIC HOSE	500200-10-08/241T-08/500200-10-08/L=1100	4	
102	3133073	HYDRAULIC HOSE	500200-10-08/241T-08/A50064-10-08/L=1100	2	

90025642  
L= 6200

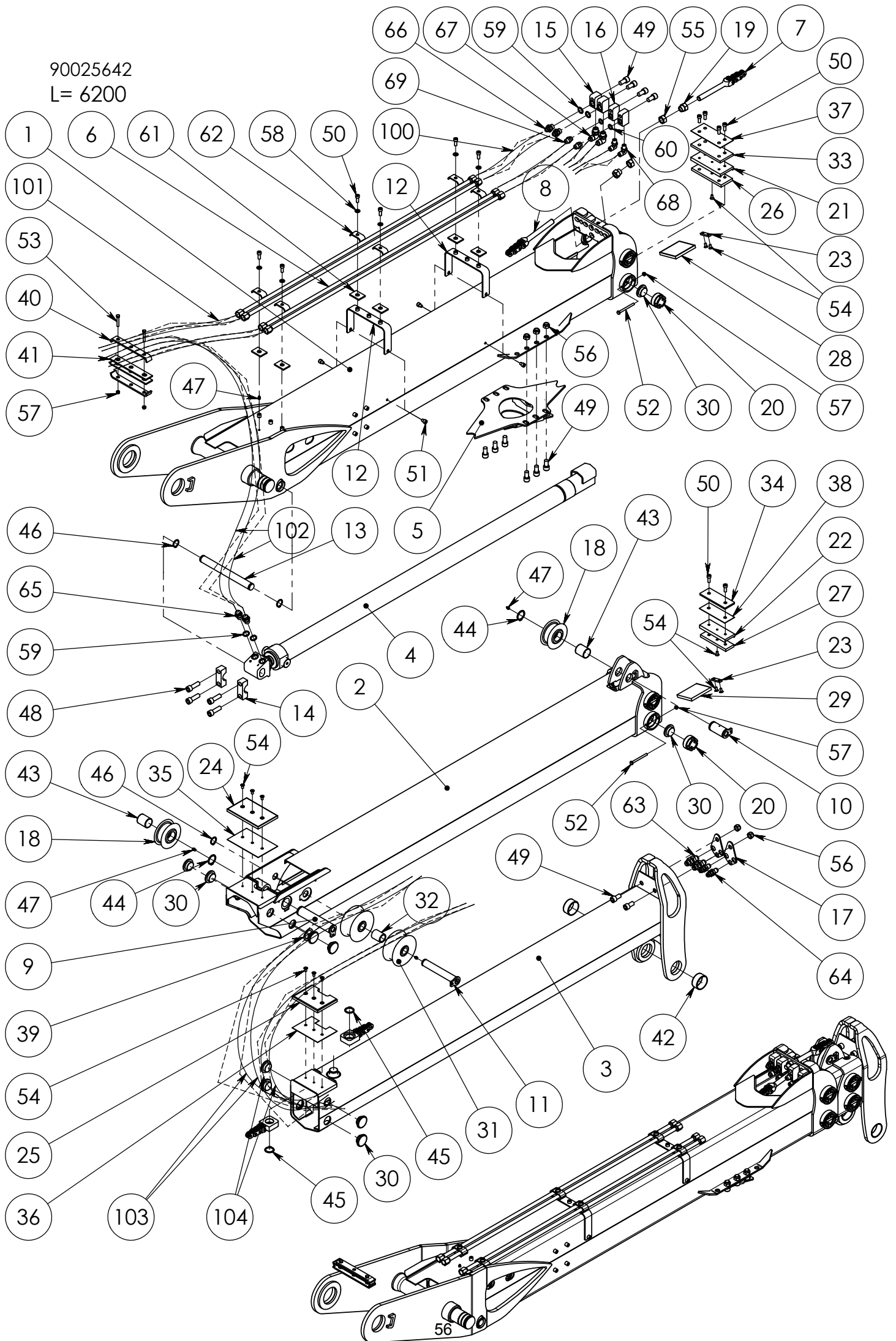



Item code	90025642	Revision	A
Title	OUTER BOOM	Date	03.07.2012
Specification	L=6200 2-JATK		

Pos	Item code	Title	Specification	Pc	Nto Weight
1	90025643	OUTER BOOM	L=2845 HITS+KON	1	157.62
2	90025646	EXTENSION 1	L= 2450	1	79.23
3	90023015	EXTENSION 2	L=2170	1	72.23
4	28870001	CYLINDER	70/40X1550	1	29.6
5	90021531	RACK	HITS	1	6.75
6	90021148	PIPE	L=1420	4	1.12
7	90021171	CHAIN	3X4 (77 LENKKIÄ )	1	1.47
8	90021172	CHAIN	3X4 (87 LENKKIÄ )	1	1.47
9	90023019	AXLE	40-203	1	1.94
10	90023021	AXLE	40-88	1	0.82
11	90023024	AXLE	30-203	1	1.07
12	90025729	FASTENER	L=224 HITS	2	0.6
13	90018765	AXLE	30-304	1	1.68
14	90019106	COVER		2	0.37
15	90019105	CONNECTOR	R 1/2"	2	0.41
16	90023027	CONNECTOR	R 3/8"	2	0.39
17	90019118	FASTENER	R / JIC	2	0.14
18	90021697	WHEEL	R1", 3X4, D90	2	1.96
19	90017520	NUT	M20-30	2	0.09
20	90016090	FASTENER		8	0.35
21	90020556	FASTENER	L-180	1	1.18
22	90023050	FASTENER		1	0.77
23	90010345	HOLDER		4	0.03
24	90020561	GLIDE PAD	120X190	1	0.31
25	90014887	GLIDE PAD	120X155	1	0.24
26	90020563	GLIDE PAD	70X180	1	0.17
27	90023052	GLIDE PAD	12X50X155	1	0.08
28	90020562	GLIDE PAD	120X100	2	0.17
29	90014768	GLIDE PAD	12 X 90 X 120	2	0.15
30	90011001	GLIDE PAD	D=55-19/7	16	0.03
31	90023054	ROLL		2	0.78
32	90024481	SLEEVE	40/31-48	1	0.02
33	90023238	PLATE		1	1.09
34	90023239	PLATE		1	0.43
35	90020566	PLATE	119X190	1	0.18
36	90017085	PLATE	119X155	1	0.13

Item code	90025642	Revision	A
Title	OUTER BOOM	Date	03.07.2012
Specification	L=6200 2-JATK		

Pos	Item code	Title	Specification	Pc	Nto Weight
37	90020567	PLATE	80X180	1	0.11
38	90023240	PLATE	60 X 155	1	0.07
39	21039422	SHIM	1XD=55	1	0.01
40	90013744	FASTENER		2	0.32
41	90013489	RUBBER	5X40X220	2	0.06
42	3100225	BUSHING	WB 802 6030	2	0.11
43	3100188	BUSHING	WB 802 4050	2	0.1
44	3060100	SNAP RING	AS 40X2.5 ZN DIN 471	2	0
45	3060091	SNAP RING	AS 35X2.5 ZN DIN 471	2	0.01
46	3060092	SNAP RING	AS 30X2 ZN DIN 471	3	0
47	3050003	GREASE NIPPLE	M8X1,25 DIN 71412	4	0
48	3010301	ALLEN SCREW	M16X50 12.9 DIN 912	4	0
49	3010700	ALLEN SCREW	M16X30 8.8 ZN DIN 912	12	0
50	3010685	ALLEN SCREW	M10X25 8.8 ZN DIN 912	12	0
51	3010297	ALLEN SCREW	M10X12 8.8 ZN DIN 912	4	0
52	3010328	HEW SCREW	M8X90 8.8 ZN DIN 931	8	0
53	3010072	HEW SCREW	M8X50 8.8 ZN DIN 931	2	0
54	3010190	ALLEN SCREW	M8X16 10.9 DIN 7991	16	0
55	3020032	NUT	M20 ZN DIN 934/8	2	0
56	3020010	NUT	M16 ZN DIN 985	8	0.03
57	3020001	NUT	M8 ZN DIN 985	10	0.01
58	3030003	WASHER	M10/11 ZN DIN 126	6	0
59	3110042	USIT-SEAL	R-08 R 1/2"	4	0.01
60	3110040	USIT-SEAL	R-06 R 3/8"	2	0
61	90010443	RUBBER	5X55-40	6	0.01
62	90010442	FASTENER	LT4X30-72	6	0.07
63	3091036	CONNECTOR	1030-10-10 7/8" -7/8"	2	0.19
64	3090952	CONNECTOR	29-1030-08-08	2	0.11
65	3090289	CONNECTOR	29-6010-08-10	2	0.11
66	3090485	CONNECTOR	6010-08-08	2	0.09
67	3090288	CONNECTOR	6310-08-10 R 1/2"- JIC 7/8"	2	0.18
68	3090630	CONNECTOR (ANGLE)	6310-06-08	2	0.1
69	3090604	CONNECTOR	6010-06-08	2	0.07
100	3132997	HYDRAULIC HOSE	A50005-08-08/241T-08/500200-10-08/L=600	4	
101	3132998	HYDRAULIC HOSE	500200-10-08/241T-08/500200-10-08/L=1000	4	
102	3133073	HYDRAULIC HOSE	500200-10-08/241T-08/A50064-10-08/L=1100	2	

Item code	90025642	Revision	A
Title	OUTER BOOM	Date	03.07.2012
Specification	L=6200 2-JATK		

Pos	Item code	Title	Specification	Pc	Nto Weight
103	3132999	HYDRAULIC HOSE	A50005-10-08/261E-08/A50005-10-08/L=4050	2	0
104	3133000	HYDRAULIC HOSE	A50005-08-06/261E-06/A50005-08-06/L=4050	2	

90025569

L= 5850

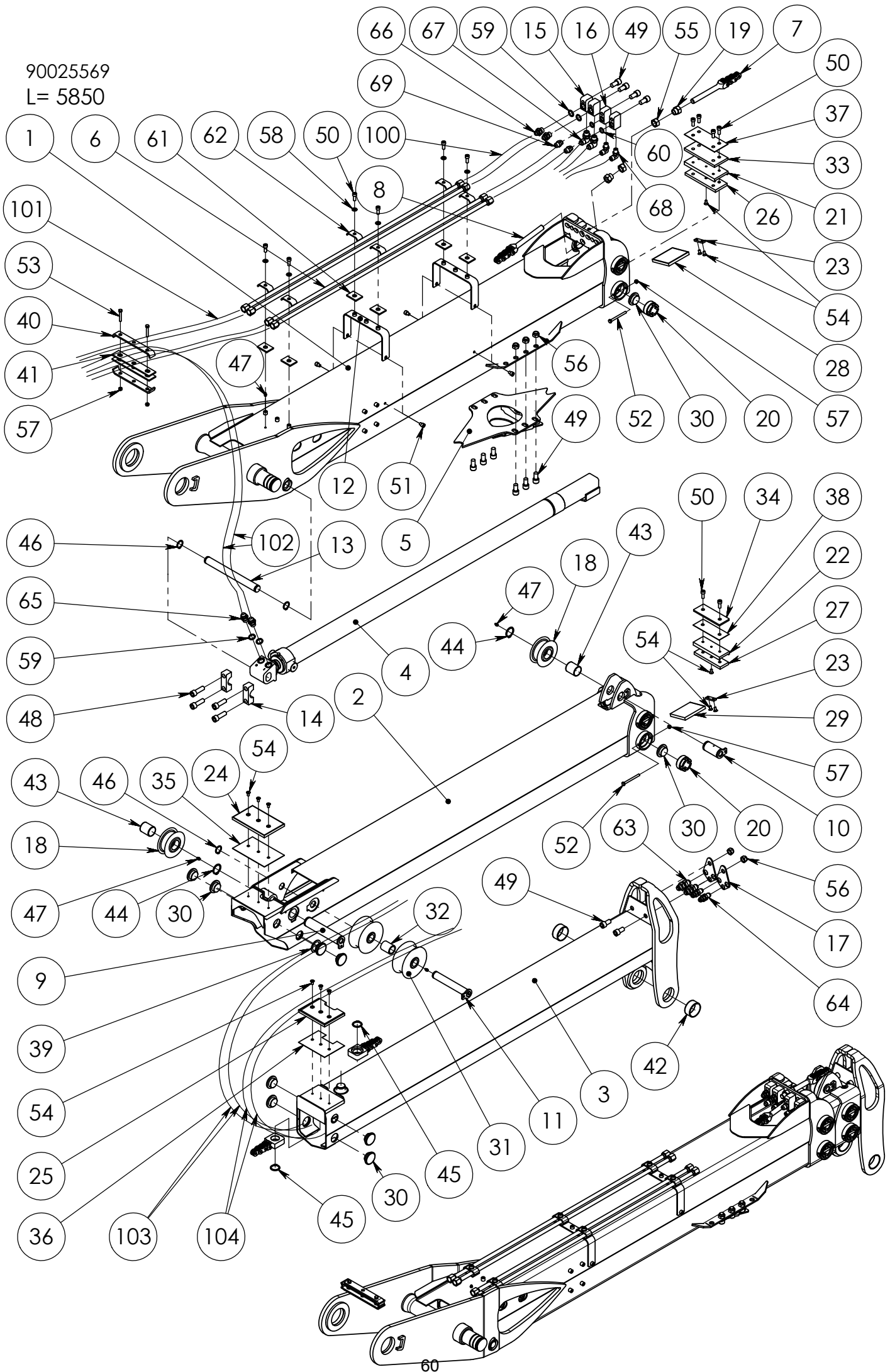

Item code	90025569	Revision	B
Title	OUTER BOOM	Date	06.06.2012
Specification	L=5850 2-JATK		

Pos	Item code	Title	Specification	Pc	Nto Weight
1	90025570	OUTER BOOM	L=2700 HITS+KON	1	153.25
2	90025591	EXTENSION 1	L= 2305	1	75.56
3	90024825	EXTENSION 2	L=2020 HITS	1	69.48
4	28658001	CYLINDER	70/40X1450	1	40.35
5	90021531	RACK	HITS	1	6.75
6	90024831	PIPE	L= 1275	4	1.02
7	90024833	CHAIN	3X4 (71 LENKKIÄ ) KOK	1	1.47
8	90021892	CHAIN	3X4 (81 LENKKIÄ ) KOK	1	1.47
9	90023019	AXLE	40-203	1	1.94
10	90023021	AXLE	40-88	1	0.82
11	90023024	AXLE	30-203	1	1.07
12	90025729	FASTENER	L=224 HITS	2	0.6
13	90018765	AXLE	30-304	1	1.68
14	90019106	COVER		2	0.37
15	90019105	CONNECTOR	R 1/2"	2	0.41
16	90023027	CONNECTOR	R 3/8"	2	0.39
17	90019118	FASTENER	R / JIC	2	0.14
18	90021697	WHEEL	R1", 3X4, D90	2	1.96
19	90017520	NUT	M20-30	2	0.09
20	90016090	FASTENER		8	0.35
21	90020556	FASTENER	L-180	1	1.18
22	90023050	FASTENER		1	0.77
23	90010345	HOLDER		4	0.03
24	90020561	GLIDE PAD	120X190	1	0.31
25	90014887	GLIDE PAD	120X155	1	0.24
26	90020563	GLIDE PAD	70X180	1	0.17
27	90023052	GLIDE PAD	12X50X155	1	0.08
28	90020562	GLIDE PAD	120X100	2	0.17
29	90014768	GLIDE PAD	12 X 90 X 120	2	0.15
30	90011001	GLIDE PAD	D=55-19/7	16	0.03
31	90023054	ROLL		2	0.78
32	90024481	SLEEVE	40/31-48	1	0.02
33	90023238	PLATE		1	1.09
34	90023239	PLATE		1	0.43
35	90020566	PLATE	119X190	1	0.18
36	90017085	PLATE	119X155	1	0.13

Item code	90025569	Revision	B
Title	OUTER BOOM	Date	06.06.2012
Specification	L=5850 2-JATK		

Pos	Item code	Title	Specification	Pc	Nto Weight
37	90020567	PLATE	80X180	1	0.11
38	90023240	PLATE	60 X 155	1	0.07
39	21039422	SHIM	1XD=55	1	0.01
40	90013744	FASTENER		2	0.32
41	90013489	RUBBER	5X40X220	2	0.06
42	3100225	BUSHING	WB 802 6030	2	0.11
43	3100188	BUSHING	WB 802 4050	2	0.1
44	3060100	SNAP RING	AS 40X2.5 ZN DIN 471	2	0
45	3060091	SNAP RING	AS 35X2.5 ZN DIN 471	2	0.01
46	3060092	SNAP RING	AS 30X2 ZN DIN 471	3	0
47	3050003	GREASE NIPPLE	M8X1,25 DIN 71412	4	0
48	3010301	ALLEN SCREW	M16X50 12.9 DIN 912	4	0
49	3010700	ALLEN SCREW	M16X30 8.8 ZN DIN 912	12	0
50	3010685	ALLEN SCREW	M10X25 8.8 ZN DIN 912	12	0
51	3010297	ALLEN SCREW	M10X12 8.8 ZN DIN 912	4	0
52	3010328	HEW SCREW	M8X90 8.8 ZN DIN 931	8	0
53	3010072	HEW SCREW	M8X50 8.8 ZN DIN 931	2	0
54	3010190	ALLEN SCREW	M8X16 10.9 DIN 7991	16	0
55	3020032	NUT	M20 ZN DIN 934/8	2	0
56	3020010	NUT	M16 ZN DIN 985	8	0.03
57	3020001	NUT	M8 ZN DIN 985	10	0.01
58	3030003	WASHER	M10/11 ZN DIN 126	6	0
59	3110042	USIT-SEAL	R-08 R 1/2"	4	0.01
60	3110040	USIT-SEAL	R-06 R 3/8"	2	0
61	90010443	RUBBER	5X55-40	6	0.01
62	90010442	FASTENER	LT4X30-72	6	0.07
63	3091036	CONNECTOR	1030-10-10 7/8" -7/8"	2	0.19
64	3090952	CONNECTOR	29-1030-08-08	2	0.11
65	3090289	CONNECTOR	29-6010-08-10	2	0.11
66	3090485	CONNECTOR	6010-08-08	2	0.09
67	3090288	CONNECTOR	6310-08-10 R 1/2"- JIC 7/8"	2	0.18
68	3090630	CONNECTOR (ANGLE)	6310-06-08	2	0.1
69	3090604	CONNECTOR	6010-06-08	2	0.07
100	3132997	HYDRAULIC HOSE	A50005-08-08/241T-08/500200-10-08/L=600	4	
101	3132998	HYDRAULIC HOSE	500200-10-08/241T-08/500200-10-08/L=1000	4	
102	3133073	HYDRAULIC HOSE	500200-10-08/241T-08/A50064-10-08/L=1100	2	

Item code	90025569	Revision	B
Title	OUTER BOOM	Date	06.06.2012
Specification	L=5850 2-JATK		

Pos	Item code	Title	Specification	Pc	Nto Weight
103	3133066	HYDRAULIC HOSE	A50005-10-08/261E-08/A50005-10-08/L=3750	2	
104	3133067	HYDRAULIC HOSE	A50005-08-06/261E-06/A50005-08-06/L=3750	2	

90025497

2109Z, 2110Z DRAW BAR

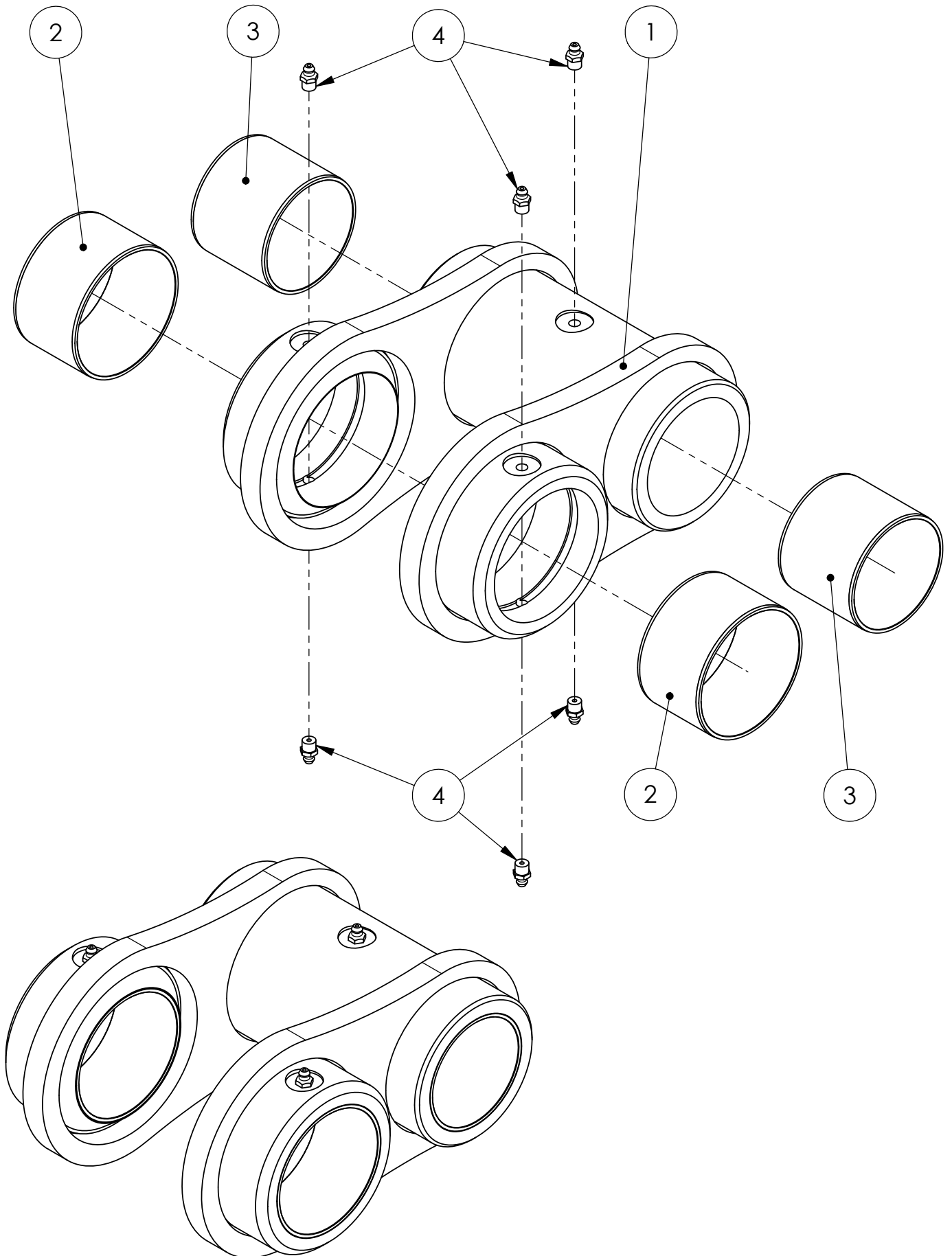



Item code	90025497	Revision	-
Title	DRAW BAR	Date	21.05.2012
Specification	VAR		

Pos	Item code	Title	Specification	Pc	Nto Weight
1	90025490	LINK	HITS+KON	1	9.66
2	3100178	BUSHING	WB 802 8050	2	0.25
3	3100185	BUSHING	WB 802 7060	2	0.27
4	3050003	GREASE NIPPLE	M8X1,25 DIN 71412	6	0

90021171

3 x 4 / 77 LINKS

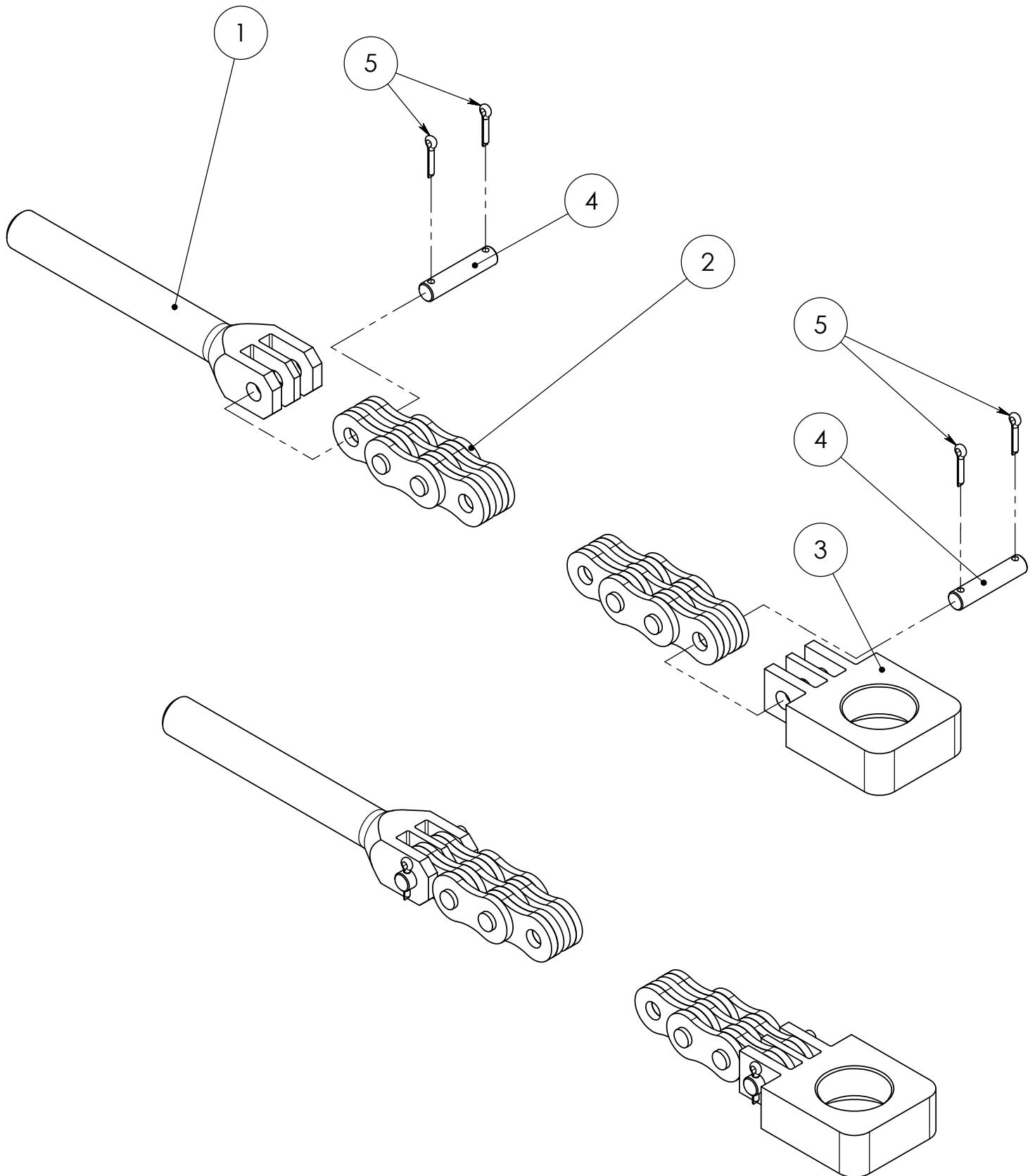

Item code	90021171	Revision	A
Title	CHAIN	Date	09.05.2006
Specification	3X4 (77 LENKKIÄ)		

Pos	Item code	Title	Specification	Pc	Nfo Weight
1	90021136	TENSIONER	R 1"	1	0.52
2	3190111	CHAIN	LH 1634 L=1956 77 LENKKIÄ	1	0.33
3	90021137	CONNECTOR	R 1"	1	0.53
4	3190184	PIN	LIITINTAPPI D=9,53-43,7 KETJULLE BL834	2	0.02
5	3040060	COTTER PIN	3,2X20 ZN DIN 94	4	0

90021172

3 x 4/ 87 LINKS

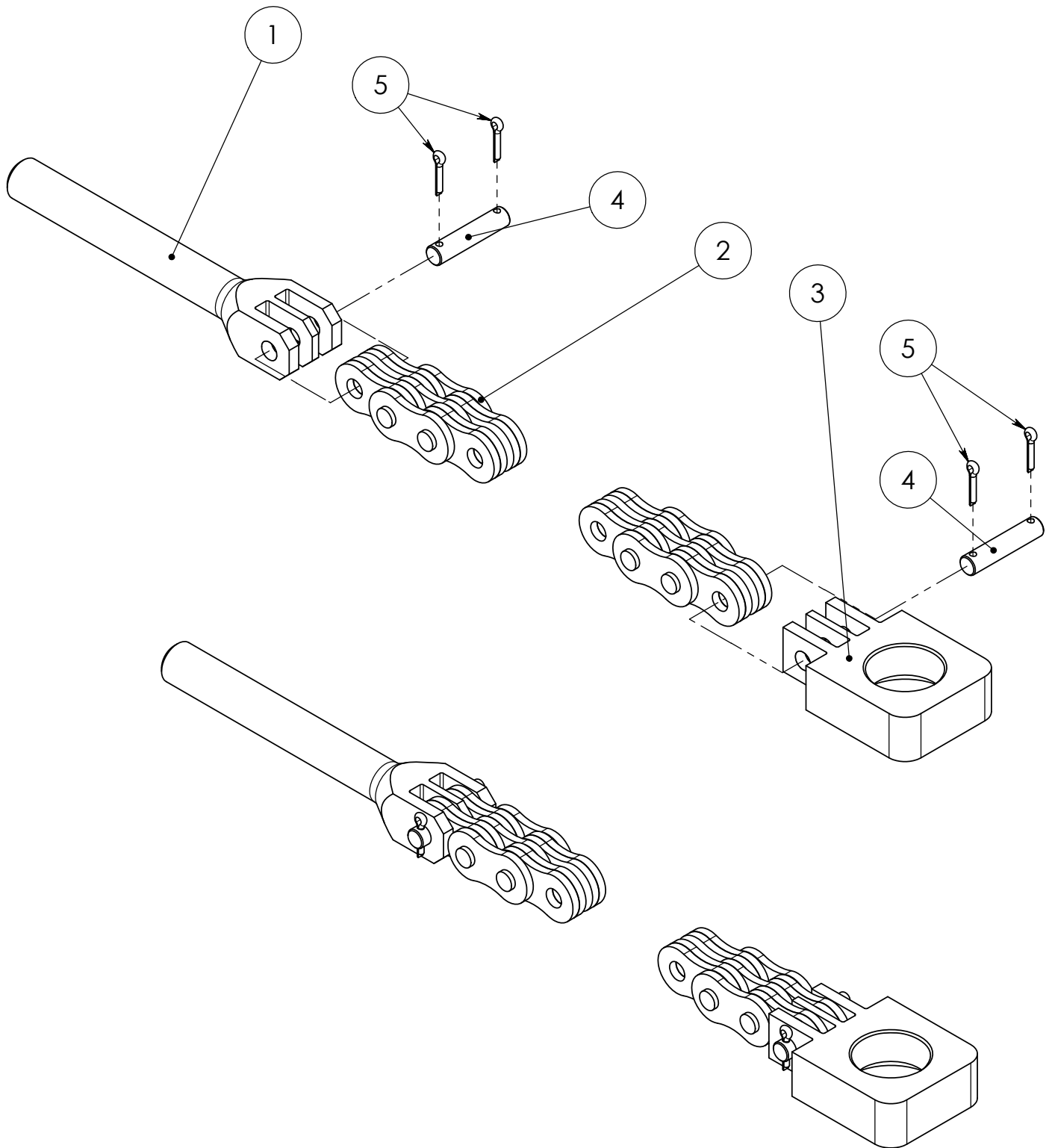

Item code	90021172	Revision	A
Title	CHAIN	Date	10.05.2006
Specification	3X4 (87 LENKKIÄ )		

Pos	Item code	Title	Specification	Pc	Nto Weight
1	90021136	TENSIONER	R 1"	1	0.52
2	3190112	CHAIN	LH 1634 L=2210 ( 87 LENKKIÄ )	1	0.33
3	90021137	CONNECTOR	R 1"	1	0.53
4	3190184	PIN	LIITINTAPPI D=9,53-43,7 KETJULLE BL834	2	0.02
5	3040060	COTTER PIN	3,2X20 ZN DIN 94	4	0

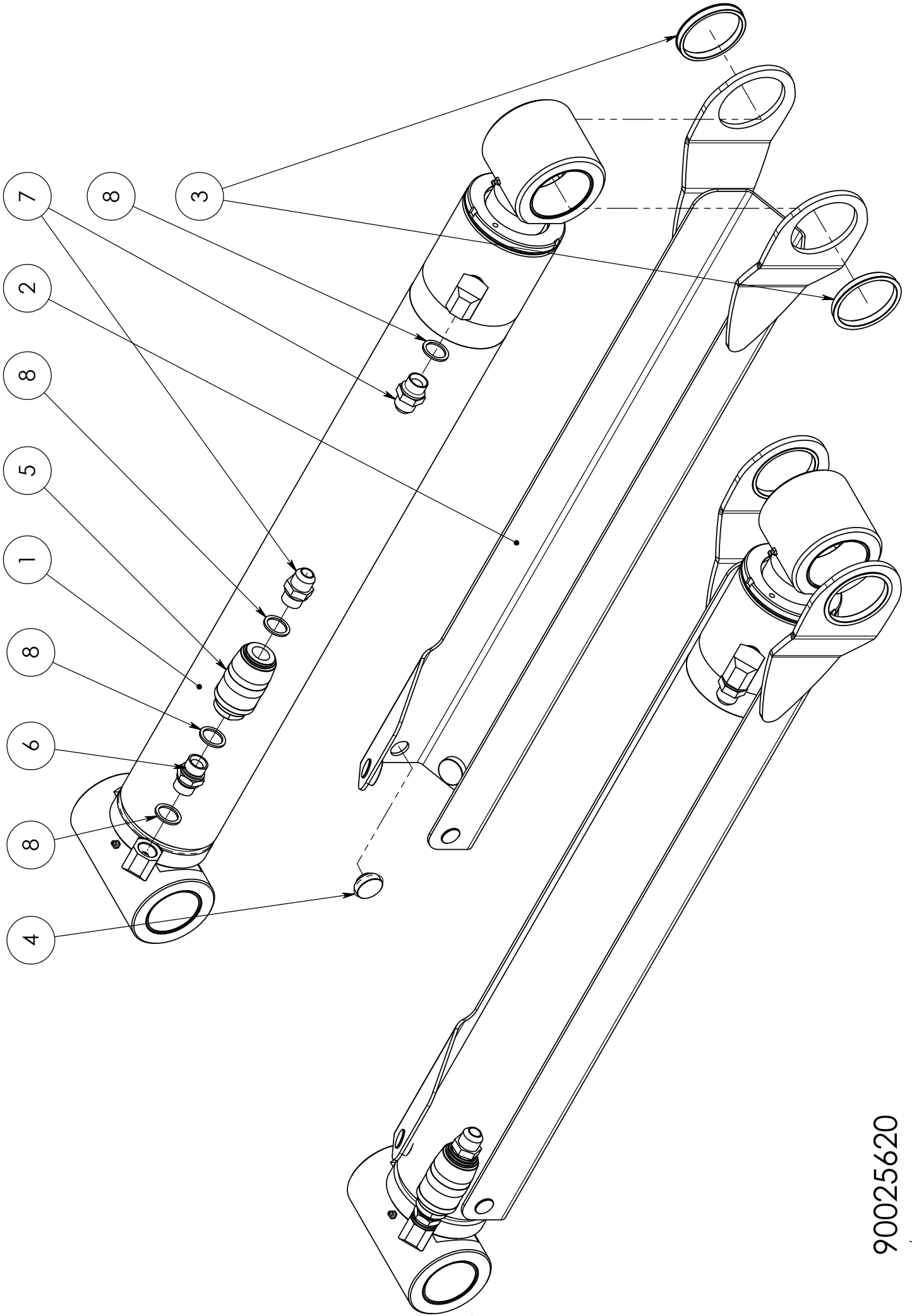



## SPARE PART LIST

Item code	90025620	Revision	-
Title	CYLINDER	Date	27.06.2012
Specification	120/80 X 921 NOSTOSYLINTERI 2109Z		

Pos	Item code	Title	Specification	Pc	Nto Weight
1	28923001	CYLINDER	120/80-921	1	78.69
2	90024293	COVER	NOSTOSYL SUOJA HITS	1	13.64
3	90025618	SLEEVE	93/81-10	2	0.01
4	21038406	GUIDE PAD	35/25-16	5	0.01
5	3120235	CHECK VALVE		1	1.24
6	3090185	CONNECTOR (STRAIGHT)	04000-12	1	0.14
7	3090918	CONNECTOR (STRAIGHT)	R 3/4" -1 1/16" JIC 26-04001-12-12	2	0.16
8	3110130	USIT-SEAL	R-12 R 3/4"	4	0.01

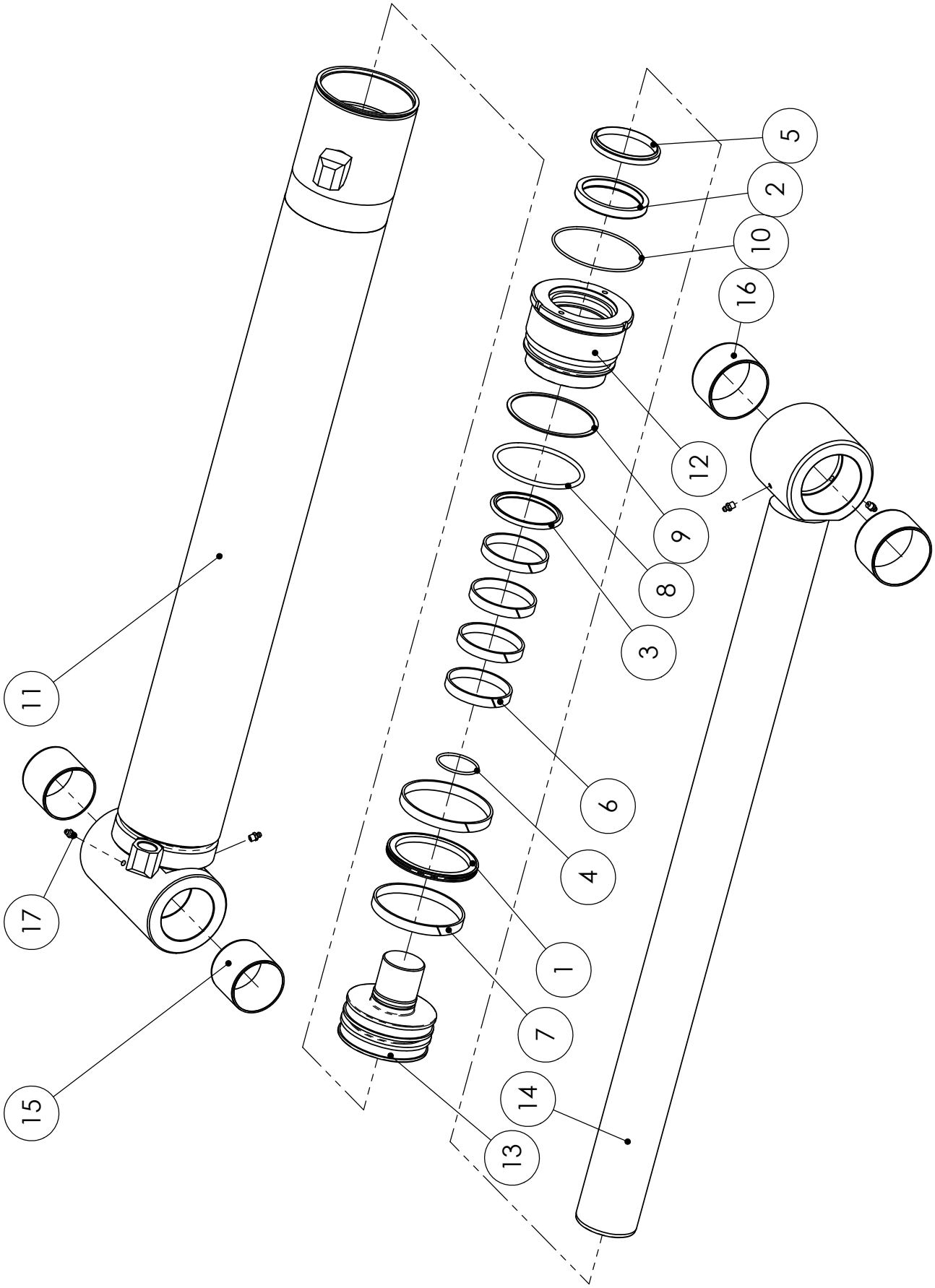

28923001 SYLINTERI

VARAOSAT \ RESERVDELAR \ SPARE PARTS \ ERSATZTEIL





## SPARE PART LIST

Item code	28923001	Revision	-
Title	SYLINTERI	Date	27.06.2012
Specification	120/80-921		

Pos	Item code	Title	Specification	Dimensions	Pc	Amount	Unit	Nto Weight
1	3110813	MÄNNÄNTIIVISTE KOLV TÄTNING PISTON SEAL KOLBENDICHTUNG	OK 120/99X8		1			0.22
2	3110251	VARRENTIIVISTE KOLVSTÄNGSTÄTNING ROD SEAL DICHTUNG FÜR KOLBENSTANGE	NI 300 80/95X12		1			0.16
3	3110880	VARRENTIIVISTE KOLVSTÄNGSTÄTNING ROD SEAL DICHTUNG FÜR KOLBENSTANGE	OMS-MR 80/95.1X6		1			0.08
4	3110182	O-RENGAS O-RING O-RING O-RING	50.2X3 90 SHORE		1			0.01
5	3110111	LUOVUTIN AVSTRYKARE WIPER SEAL ABSTREIFER	GA 80/90X7/10		1			0.08
6	3110788	OHJAIN STYRNING GUIDANCE STEUERUNG	I/PWR 80/86X13		4			0.08
7	3110814	MÄNNÄNOHJAIN KOLV STYRNING PISTON GUIDE KOLBENFÜHRUNG	E/PWR 120/114X13		2			0.11
8	3110277	O-RENGAS O-RING O-RING O-RING	109.2X5.7 90 SHORE		1			0.07
9	3110200	TUKIRENGAS STÖDRING SUPPORTING RING-STÜTZRING	120/110X1.7 PU		1			0
10	3110400	O-RENGAS O-RING O-RING O-RING	114.5X3.0 90 SHORE		1			0.02
11	28923101	SYLINTERIPUTKI CYLINDER RÖR CYLINDER BARREL ZYLINDERROHR	120/80-921		1			15.72
12	28923202	OHJAIN STYRNING GUIDANCE STEUERUNG	120/80	L=100	1			4.03
13	28923201	MÄNTÄ KOLV PISTON KOLBEN	120	L=1	1			4.34
14	28923204	MÄNNÄNVARSI KOLVSTÄNG PISTON ROD KOLBENSTANGE	80/50-1048		1			9.12
15	3100185	LIUKULAAKERI BUSSNING BUSHING GLEITLAGER	WB 802 7060		2			0.27
16	3100178	LIUKULAAKERI BUSSNING BUSHING GLEITLAGER	WB 802 8050		2			0.25
17	3050003	RASVANIPPA SMÖRJNIPPEL GREASE NIPPLE SCHMIERNIPPEL	M8X1.25 DIN 71412		4			0
-10	3111026	TIIVISTESARJA TÄTNINGSSETTS SEAL KIT DICHTUNGSSATZ	120/80		1			

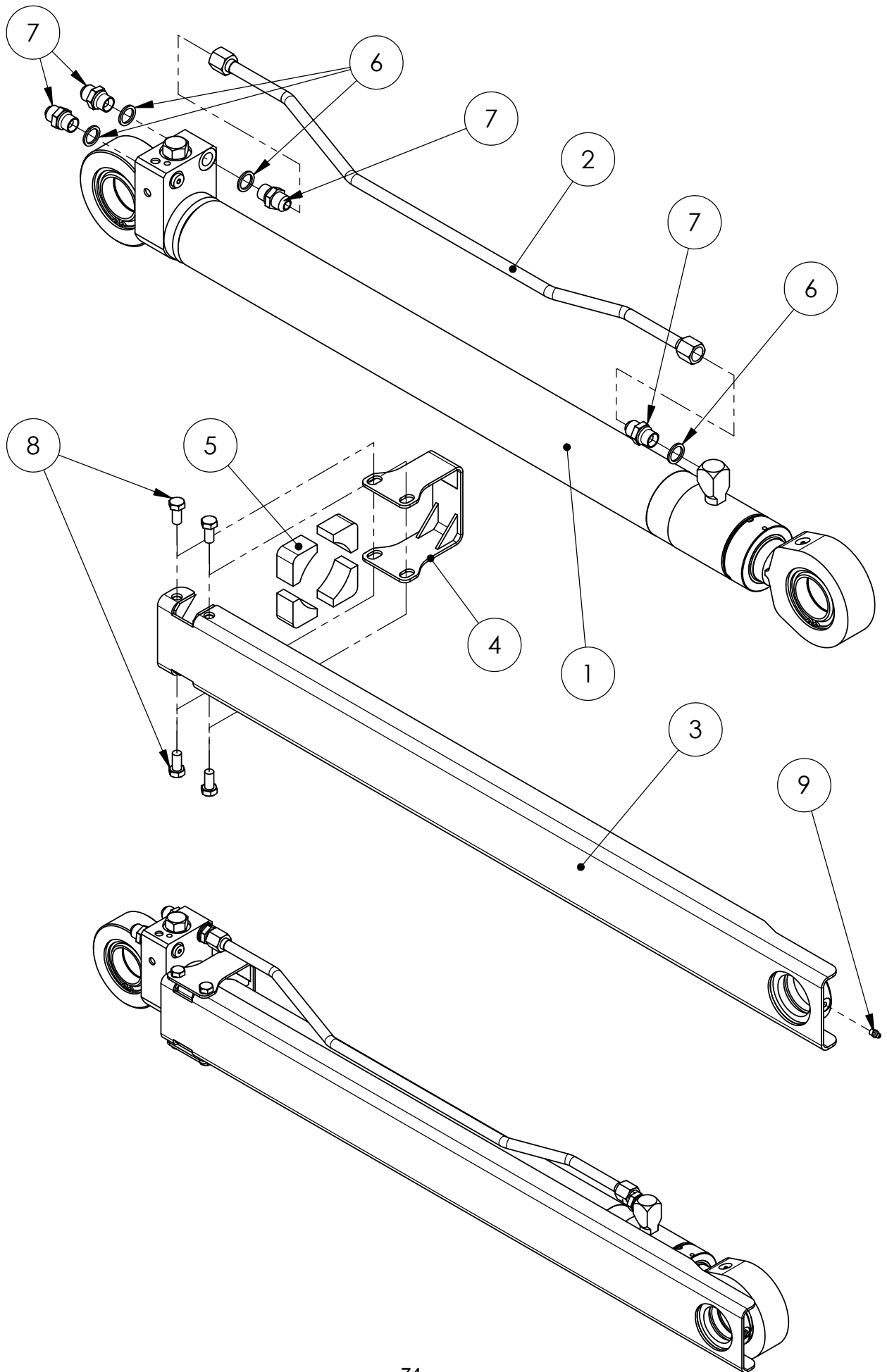

Item code	90025549	Revision	-
Title	CYLINDER	Date	30.05.2012
Specification	80/60X880 VAR		

Pos	Item code	Title	Specification	Pc	Nto Weight
1	28907001	CYLINDER	80/60X880	1	59.19
2	90022950	HYDRAULIC PIPE	KOK	1	0.77
3	90025550	COVER	HITS	1	7.76
4	90025552	FASTENER	HITS	1	0.7
5	90023630	GLIDE PAD	12.5/45X30	4	0.05
6	3110042	USIT-SEAL	R-08 R 1/2"	4	0.01
7	3090917	CONNECTOR (STRAIGHT)	26-040010810 R 1/2" -7/8" JIC	4	0.11
8	3010442	HEW SCREW	M12X25 8.8 ZN DIN 933	4	0
9	3050003	GREASE NIPPLE	M8X1,25 DIN 71412	1	0

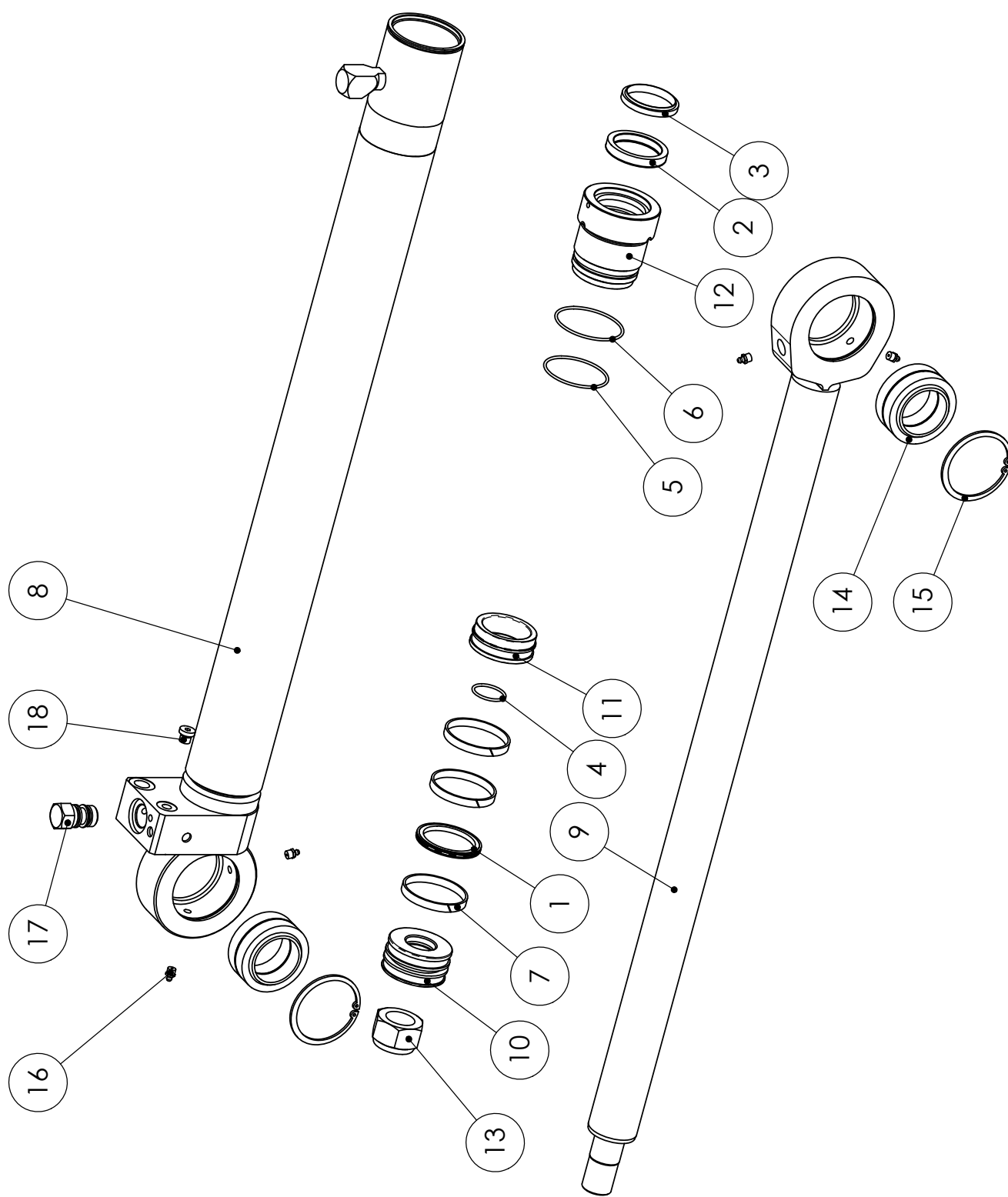

28907001 SYLINTERI

VARAOSAT \ RESERVDELAR \ SPARE PARTS \ ERSATZTEIL



## SPARE PART LIST

Item code	28907001	Revision	-
Title	SYLINTERI	Date	08.05.2012
Specification	80/60X880		

Pos	Item code	Title	Specification	Dimensions	Pc	Amount	Unit	Nto Weight
1	3110810	MÄNNÄNTIIVISTE KOLV TÄTNIING PISTON SEAL KOLBENDICHTUNG	300 80/64.5X6		1			0.08
2	3110315	VARRENTIIVISTE KOLVSTÄNGTÄTNIING ROD SEAL DICHTUNG FÜR KOLBENSTANGE	60/75X11.4		1			0.11
3	3110188	LUOVUTIN AVSTRYKARE WIPER SEAL ABSTREIFER	GA 60/70X7/10		1			0.06
4	3110254	O-RENGAS O-RING O-RING O-RING	36.2X3 90 SHORE		1			0.01
5	3110033	O-RENGAS O-RING O-RING O-RING	74.5X3 90 SHORE		1			0.01
6	3110107	O-RENGAS O-RING O-RING O-RING	79.5X3 90 SHORE		1			0.01
7	3111016	OHJAIN STYRNING GUIDANCE STEUERUNG	80/75X9.7		3			0.05
8	28907101	SYLINTERIPUTKI CYLINDER BARREL ZYLINDERROHR	80/60X880		1			10.95
9	28907204	MÄNNÄNVARSI KOLVSTÄNG PISTON ROD KOLBENSTANGE	60		1			7.03
10	28847201	MÄNTÄ KOLV PISTON KOLBEN	80	L=43	1			0.92
11	28907105	HOLKKI HYLISA SLEEVE ACHSHALTER	ISKUNRAJOITIN	L=32	1			0.46
12	28907202	OHJAIN STYRNING GUIDANCE STEUERUNG	80/60		1			2.1
13	3020043	MUTTERI MUTTER NUT MUTTER	M36X3 ZN DIN 985		1			0.42
14	3100048	NIVELLAAKERILEDLAGER JOINT BEARING GELENKLÄGER	GE 60 ES		2			1.06
15	3060041	PIDÄTINRENGAS LÄSRING SNAP RING SPRENGRING	90X3 DIN 472		2			0
16	3050020	RASVANIPPA SMÖR.JNIPPEL GREASE NIPPLE SCHMIERNIPPEL	R 1/8" ZN		4			0.01
17	28836108	TULPPA PLUGG PLUG DECKEL		L=55	1			0.23
18	3090211	TULPPA PLUGG PLUG DECKEL			1			0.02
1-7	3111017	TIIVISTESARJA TÄTNIINGSSATS SEAL KIT DICHTUNGSSATZ	80/60		1			

28658001

# SYLINTERI

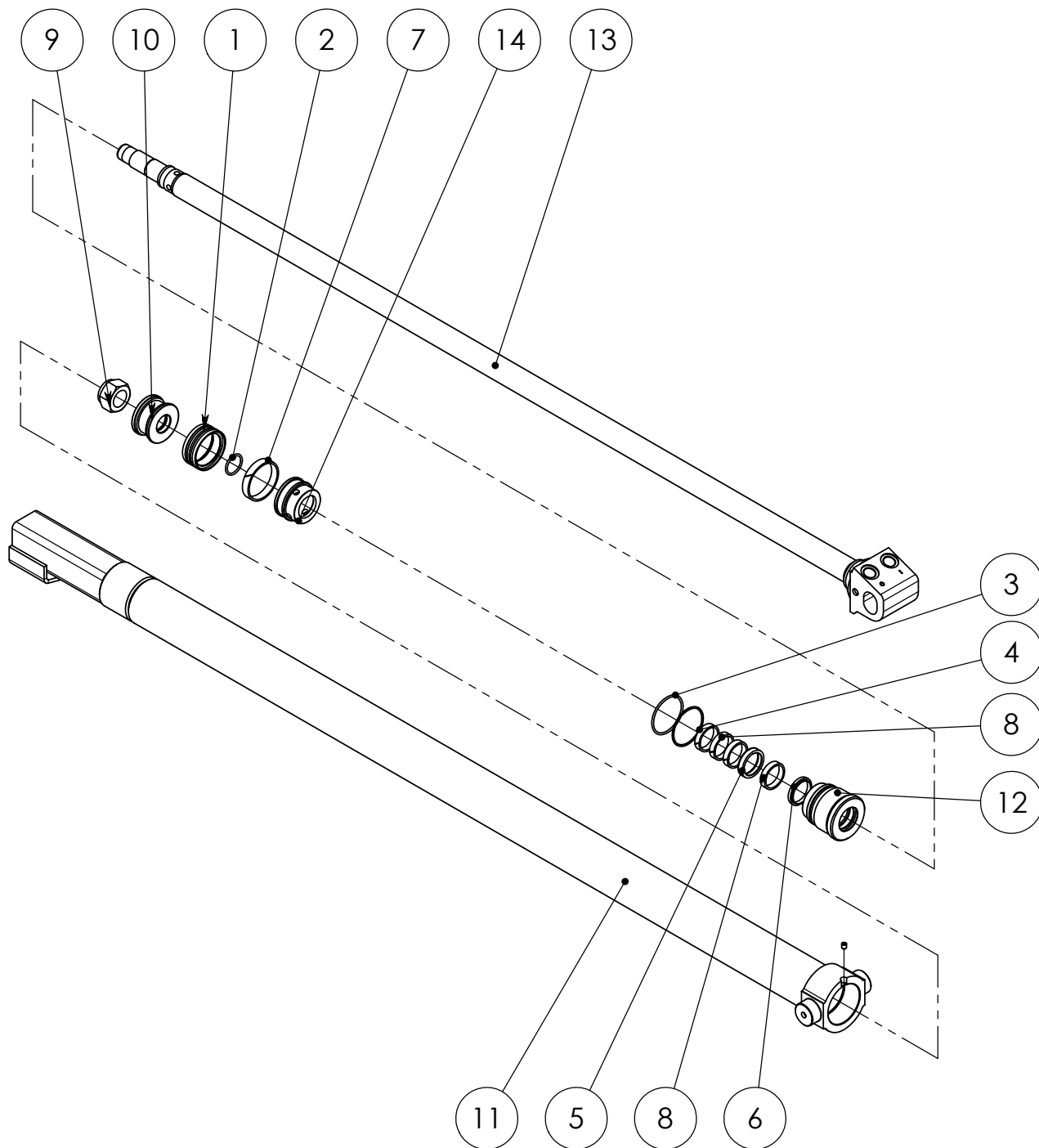

Testauspaine 270 bar

Item code	28658001	Revision	-
Title	CYLINDER	Date	11.10.2006
Specification	70/40X1450		

Pos	Item code	Title	Specification	Pc	Nto Weight
1	3110317	PISTON SEAL	PDO 70/58X20	1	0.21
2	3110248	O-RING	31.5X3 90 SHORE	1	0.01
3	3110009	O-RING	64.5X3 90 SHORE	1	0.01
4	3110557	SUPPORTING RING	70/65X1.3 PU	1	0
5	3110010	ROD SEAL	NI 300 40/50X10	1	0.05
6	3110011	WIPER SEAL	PW 40	1	0.03
7	3110697	PISTON GUIDE	E/PWR 70/64X13	1	0.06
8	3110735	GUIDANCE	I/PWR 40/46X10	4	0.03
9	3020145	NUT	M30X2 ZN DIN 980 V	1	0.24
10	28349201	PISTON	D=70 (PDO-IIIV.)	1	0.64
11	28658101	CYLINDER BARREL	70/1450	1	20.08
12	28581202	GUIDANCE	70/40	1	1.38
13	28658204	PISTON ROD	D=40	1	16.51
14	28581105	SLEEVE	ISKURAJOITIN L=42	1	0.52
15	3010175	ALLEN SCREW	M8X10 ZN DIN 914	1	0
SRJ	3110736	SEAL KIT	70/40	1	0.49

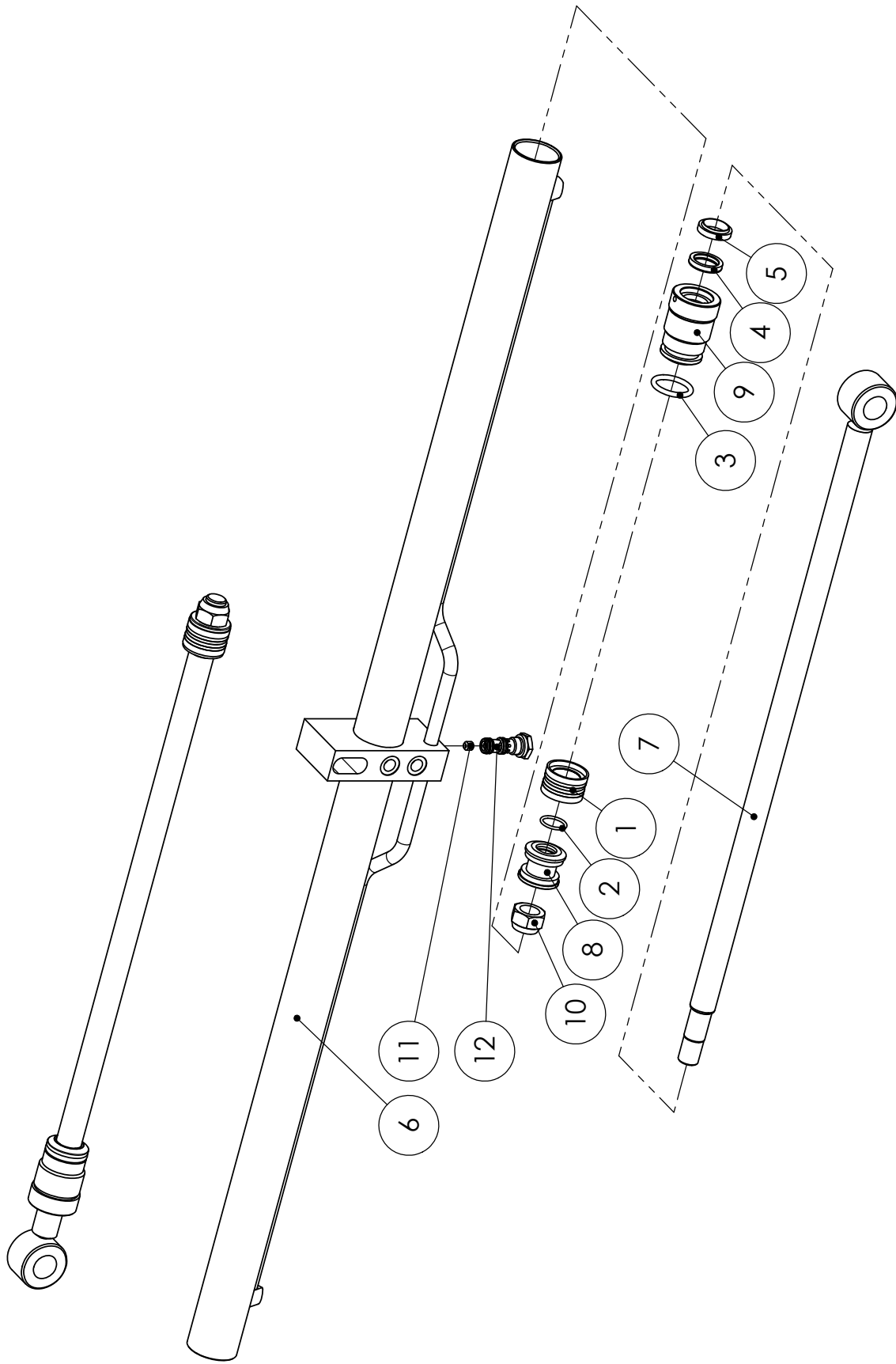

28864001 LEVITYSSYLINTERI

VARAOSAT \ RESERVDELAR \ SPARE PARTS \ ERSATZTEIL





## SPARE PART LIST

Item code	28864001	Revision	-
Title	LEVITYSSYLINTERI	Date	17.12.2012
Specification	50/30X2X650		

Pos	Item code	Title	Specification	Dimensions	Pc	Amount	Unit	Ntto Weight
1	3110013	MÄNNÄITIVISTE KOLV TÄTNING PISTON SEAL KOLBENDICHTUNG	DAS 50/34X18		2			0.18
2	3110003	O-RENGAS O-RING O-RING O-RING	26,2X3 70 SHORE		2			0.01
3	3110288	O-RENGAS O-RING O-RING O-RING	39,2X5,7 90 SHORE		2			0.03
4	3110030	VARRENTIIVISTE KOLVSTÄNGSTÄTNING ROD SEAL DICHTUNG FÜR KOLBENSTANGE	T22 30/40X7,3		2			0.02
5	3110313	LUOVUUTIN AVSTRYKARE WIPER SEAL ABSTREIFER	GA 30/40X7/10		2			0.03
6	28864101	SYLINTERIPUTKI CYLINDER BARREL ZYLINDERROHR	50/30X2X650		1			14.3
7	28772204	MÄNNÄNVARSI KOLVSTÄNG PISTON ROD KOLBENSTANGE	50/30 X 2 X 650		2			5.2
8	28337201	MÄNTÄ KOLV PISTON KOLBEN	D=50 DBM	L=43	2			0.26
9	28337202	OHJAIN STYRNING GUIDANCE STEUERUNG	50/30	L=82	2			0.82
10	3020026	MUTTERI MUTTER NUT MUTTER	M24 ZN DIN 985		2			0.11
11	21510225	KURISTIN SIRYIP RESTRICTOR DROSSEL	M10X10/D=1.0		1			0
12	3120843	VENTTIILI VENTIL VALVE VENTIL			1			0.13
1-5	3110324	TIIVISTESARJA TÄTNINGSSATS SEAL KIT DICHTUNGSSATZ	50/30		1			

MIN 1042 MAX 1662

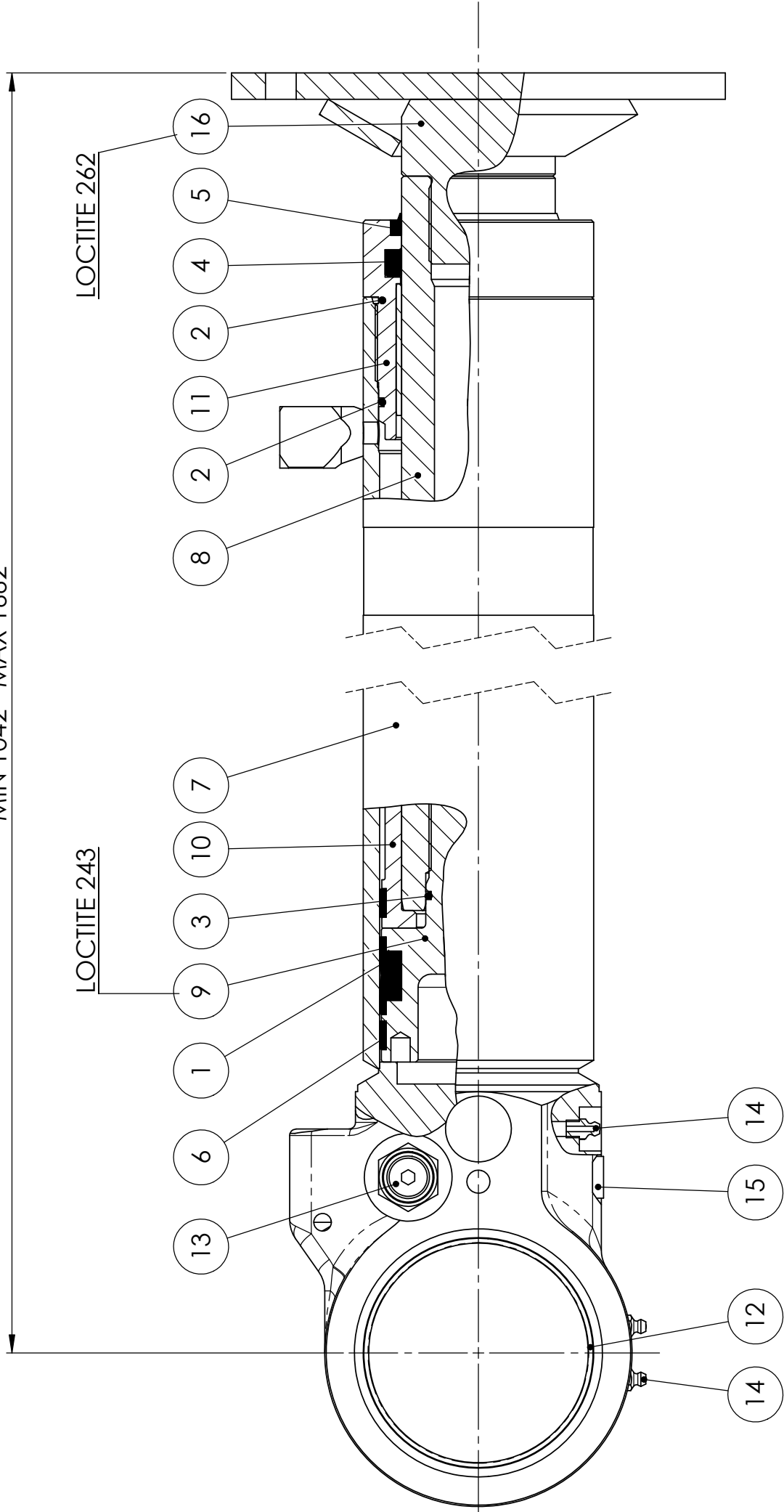



## SPARE PART LIST

Item code	28919001	Revision	-
Title	CYLINDER	Date	07.06.2012
Specification	90/70X620		

Pos	Item code	Title	Specification	Pc	Nto Weight
1	3110025	PISTON SEAL	DAS 90/70X22	1	0.5
2	3110017	O-RING	84.5X3 90 SHORE	2	0.02
3	3110258	O-RING	42.2X3 90 SHORE	1	0.01
4	3110184	ROD SEAL	B 70/85X12 POLYPAC BALSELE	1	0.17
5	3110196	WIPER SEAL	GA 70/80X7/10	1	0.07
6	3110397	PISTON GUIDE	E/PWR 90/84X13	2	0.08
7	28861101	CYLINDER BARREL	90/70X600	1	32.54
8	28919302	PISTON ROD	70	1	15.91
9	28918201	PISTON	90	1	2.4
10	28554105	SLEEVE	ISKURAJOITINHOLKKI	1	0.96
11	28358202	GUIDANCE	90/70	1	2.43
12	3100344	BUSHING	WB 802 10060	2	0.38
13	3120843	VALVE		1	0.13
14	3050003	GREASE NIPPLE	M8X1.25 DIN 71412	3	0
15	3090211	PLUG		1	0.02
16	28918106	BASE	TUKIJALKA	1	6.02
1-6	3111025	SEAL KIT	90/70	1	

90024053  
FASTENING KIT L = 1200

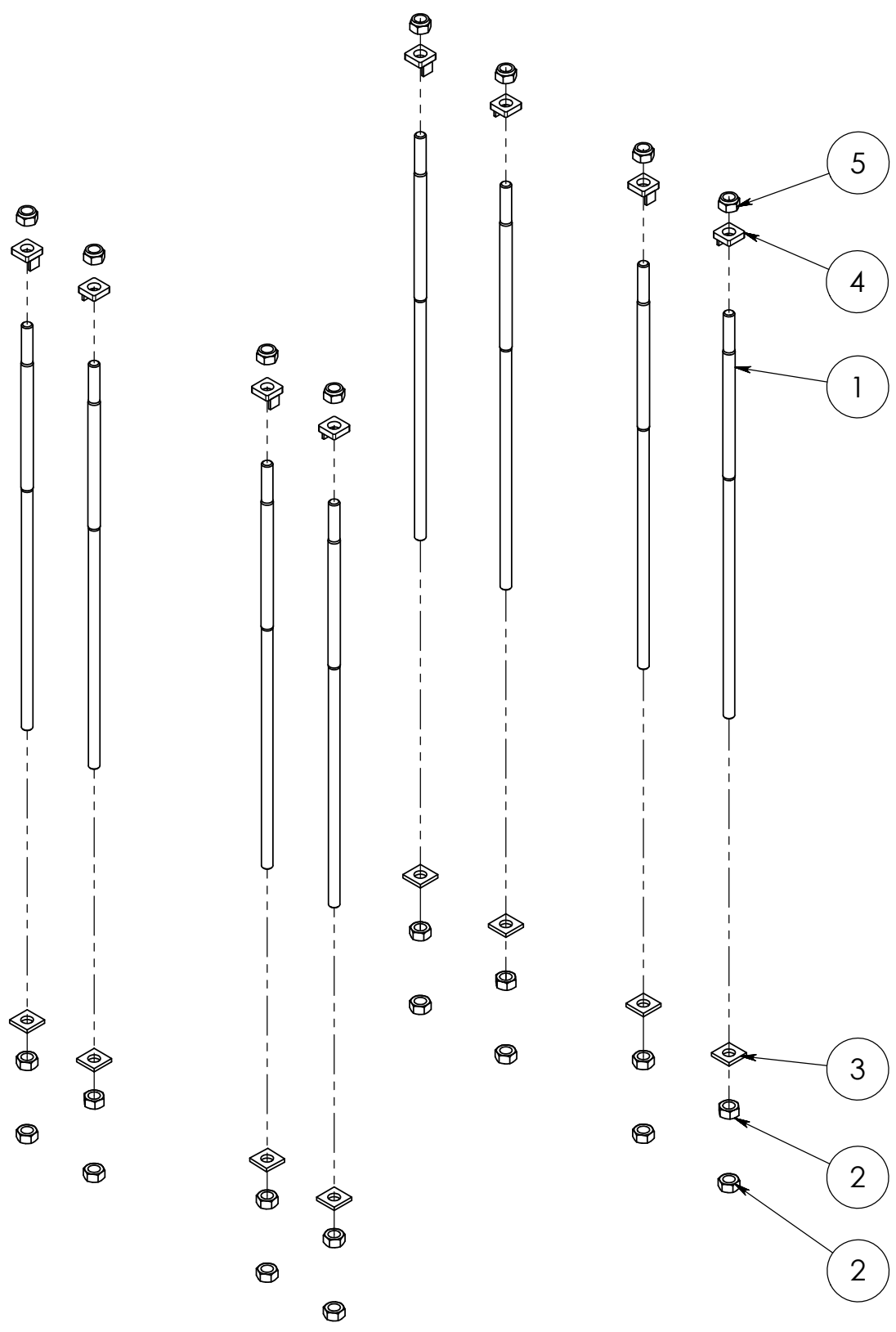

MOMENT 1200Nm (122 kpm)

Item code	90024053	Revision	A
Title	FASTENING KIT	Date	15.11.2010
Specification	L=1200		

Pos	Item code	Title	Specification	Pc	Nto Weight
1	90024052	SCREW	M30X2-1200	8	6.06
2	3020170	NUT	M30X2 ZN DIN 934	16	0
3	90014010	WASHER	60X60/31-10	8	0.22
4	90013054	WASHER	M30-16	8	0.28
5	3020041	NUT	M30X2 ZN DIN 985	8	0.24